

D THIS DRAWING AND DESIGN HEREON CONSTITUTES A PROPRIETARY DESIGN OF PACKARD ELECTRIC DIVISION AND IS NOT TO BE DUPLICATED OR REPRODUCED WITHOUT AUTHORITY OF PACKARD ELECTRIC DIVISION.

DO NOT SCALE

PART NO. 1204 5575

PART NO. 1204 5575

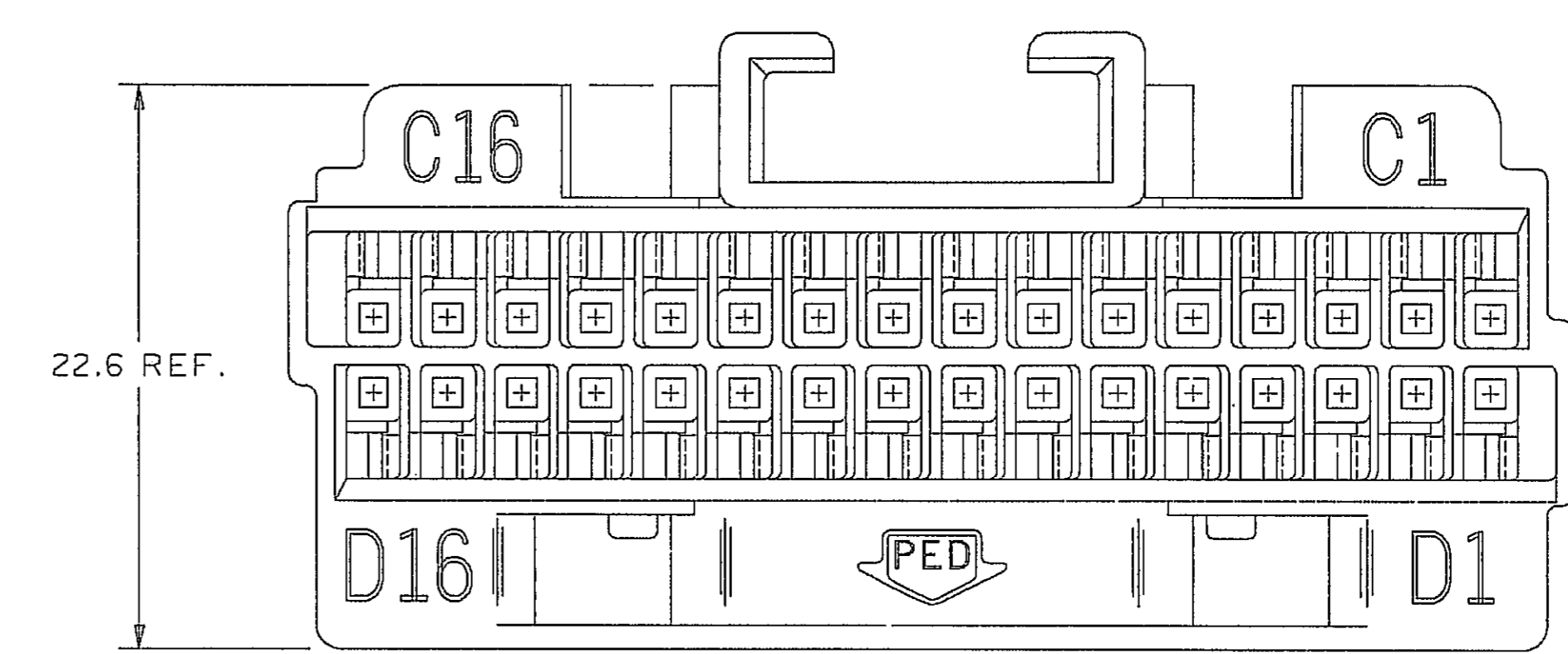
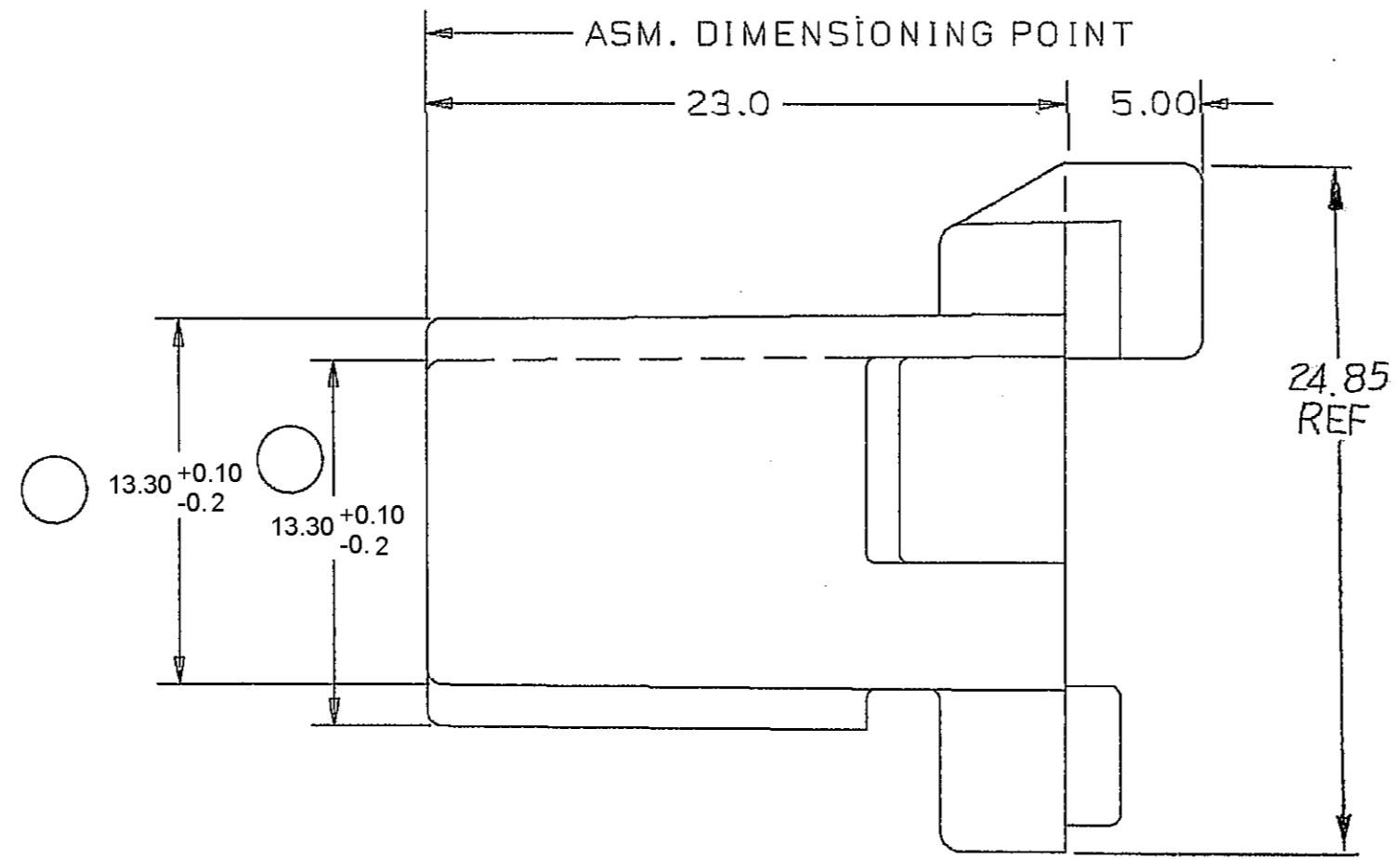
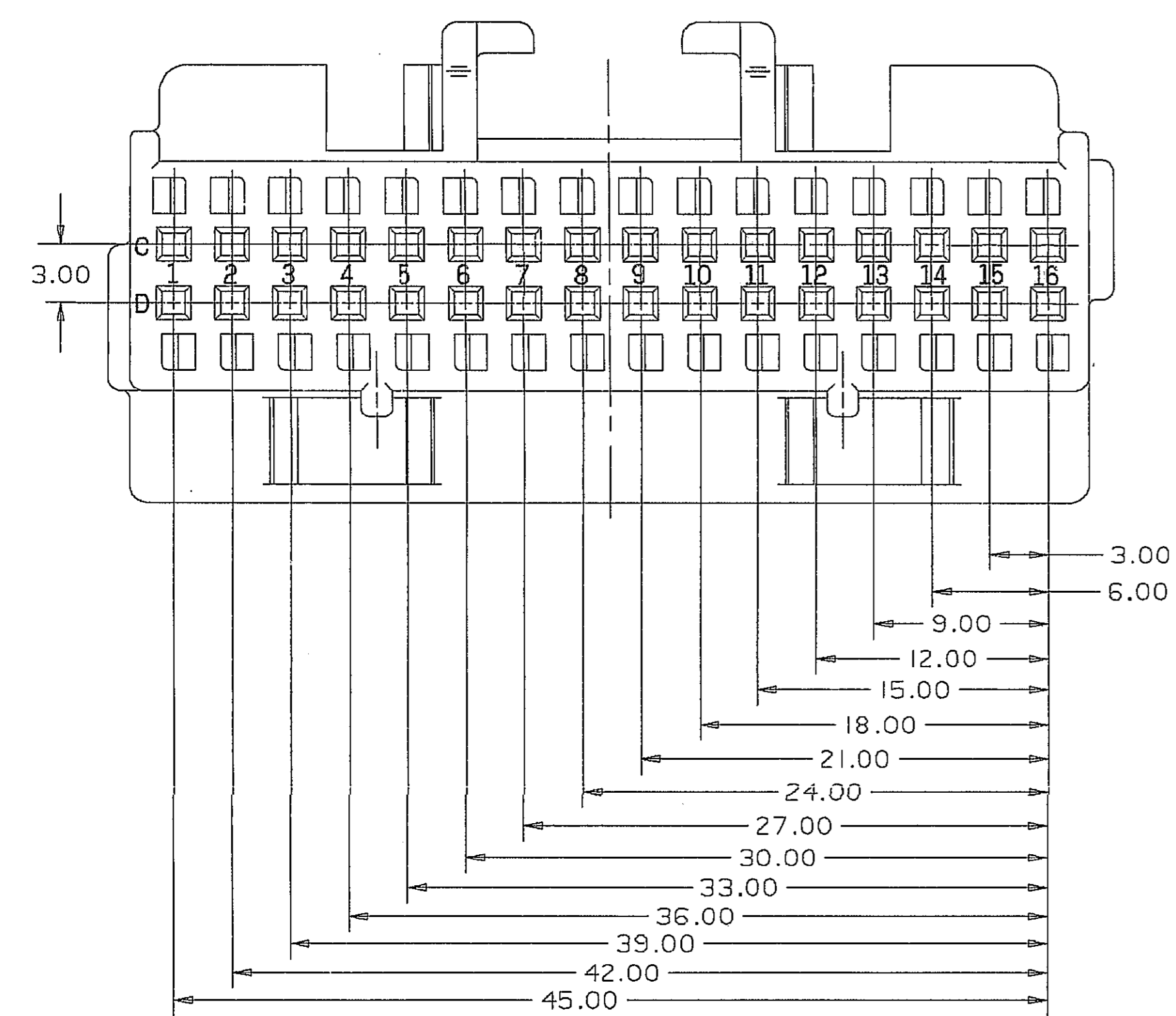
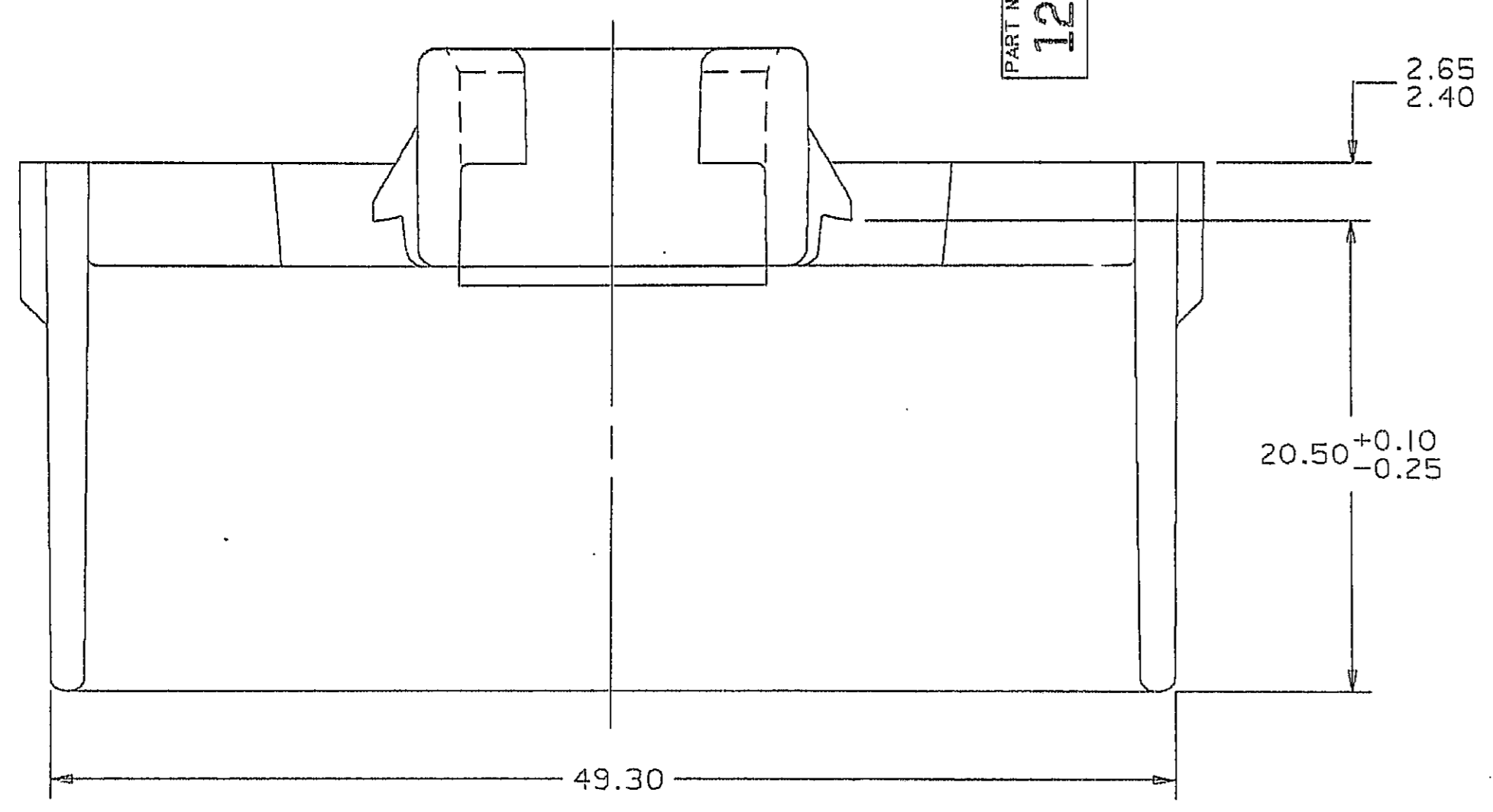

- NOTES**
1. CAVITIES C16 AND D1 CAN ACCEPT TERMINAL I2089649 OR EQUIVALENT. ALL CAVITIES CAN ACCEPT TERMINAL I2089660 OR EQUIVALENT.
 2. CAVITIES C16 AND D1 CAN ACCEPT A MAX INSULATION CRIMP OF 3.55 HIGH AND 3.50 WIDE (3.55 MAX CABLE O.D.) ALL OTHER CAVITIES ACCEPT A MAX INSULATION CRIMP OF 2.30 HIGH AND 3.50 WIDE (2.40 MAX CABLE O.D.) REFER TO ESA-605 FOR CRIMP DIMENSIONS.
 3. MATING INSULATOR I2052473, ASM I2052474 OR EQUIVALENT.
 4. USE SECONDARY LOCK I2045889 AND I2045890 FOR STRAIGHT AND I2045889 AND I2048245 FOR RIGHT ANGLE OR EQUIVALENT.

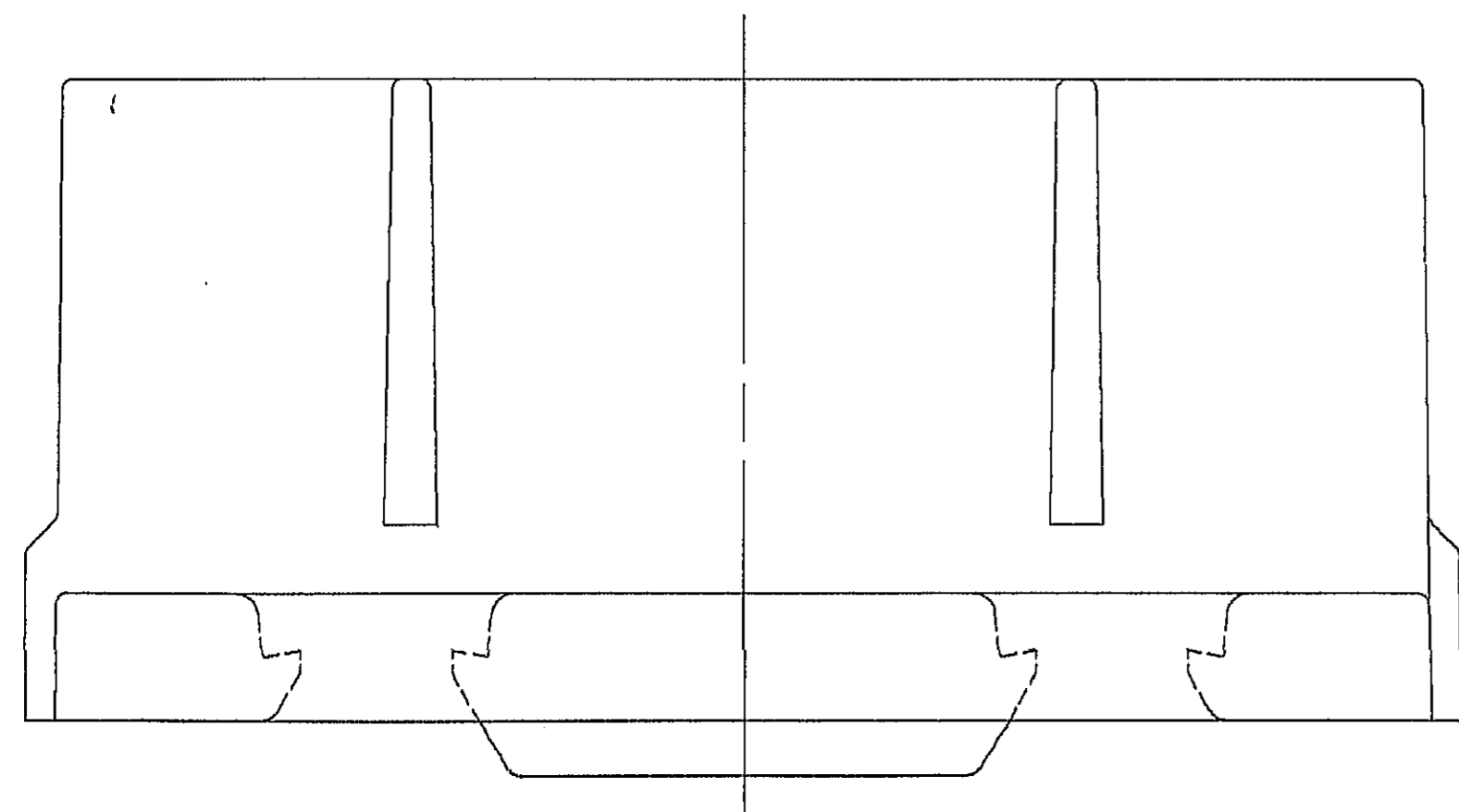

DATE	SYM	REVISION RECORD	AUTH	DR	CK
13FE84	A	RELEASED	84005		KFC
16JL84	B	REV. LEVEL ADVANCED & REPLOTED	91877	TLB	DEP
27AUG84		REVISED & REPLOTED	92632		DJJ
15JA85	C	REVISED & REPLOTED	95541	TLB	FH
21FE85		6901 CODE NO. ADDED & REPLOTED	85004	TLB	FH
03SE85	D	2.65/2.40 WAS 2.50 & 20.50 WAS 20.50			
		WAS 20.50	100454	SM	TM
28OC87		ADDED NOTES 3 & 4	116529	JEH	JM
16OC92		REVISED NOTES & ADDED DIM	15178	GH	GH
11DE95		MAT'L WAS PM002350-002	168454	JHH	JHH
24FE09	D4	DIM 13.30 +0.10/-0.2 WAS 13.30 +/-0.10 (2 PLCS) AND UPDATED MATERIAL CALLOUT	407406	AG	AG

PACKARD ELECTRIC DIVISION
GENERAL MOTORS CORPORATION
WARREN, OHIO

As of 06JL90 this drawing is no longer being maintained on computer vision.

RONART C04D1767

METRIC
DIMENSIONS ARE IN MILLIMETERS UNLESS OTHERWISE SPECIFIED

THIRD ANGLE PROJECTION

CODE NO. 6900,6901 TOLERANCE UNLESS OTHERWISE SPECIFIED
DECIMAL: ONE PLACE + 0.2 TWO PLACE + 0.10 ANGULAR: 2°

DWG. DATE 13FE84 SCALE NONE DR. CK. K. CONSTANTINE DATE 28MR84
REFERENCE NO. APPR. J.E. HILL ESTAD DATE 02AP84
I2045536 "R" SIZE APPR. DATE

MATERIAL SPEC. POLYESTER COMPOUND BLACK

NAME CONN 32F MIC/P 3MM

PART NO. 1204 5575 SIZE C
OUTLINE DRAWING