

SYMBOL DEFINITION		MISSING NUMBERS		REVISION HISTORY				AUTH	DR	APVD				
A DIMENSION WITHOUT AN INSPECTION REPORT SYMBOL  DOES NOT REQUIRE INSPECTION. IT MAY BE CONTROLLED ON AN INDIVIDUAL COMPONENT DRAWING.	TOTAL NO. OF SYMBOLS ON DRAWING	10	13,	DATE	STG	REV	N/P	CHG	ZONE	CLEARED REV COL: ALL ACTIVE PARTS - ADDED NOTES 12 PLCS1, REMOVED DIM AND REVISED MAT'L SPEC	228307	EGR	EGR	RC
	LAST NO. USED	15		05AU02	R	04	-	-	-	ALL ACTIVE PARTS - REVISED NOTE 2	229031	EGR	EGR	RC
				20N002	R	06	-	-	-	ALL ACTIVE PARTS - ADDED MATING CONNECTOR INFORMATION	233220	RCH	RCH	RC
				12JN03	R	07	-	-	-	ALL ACTIVE PARTS - REVISED MAT'L SPEC AND NOTE	242420	JYD	JYD	ET
				12N003	R	08	-	-	-	ALL ACTIVE PARTS - ADDED SEPARATION NOTE TO HINGE FLEX VIEW	248545	RH	RH	TM

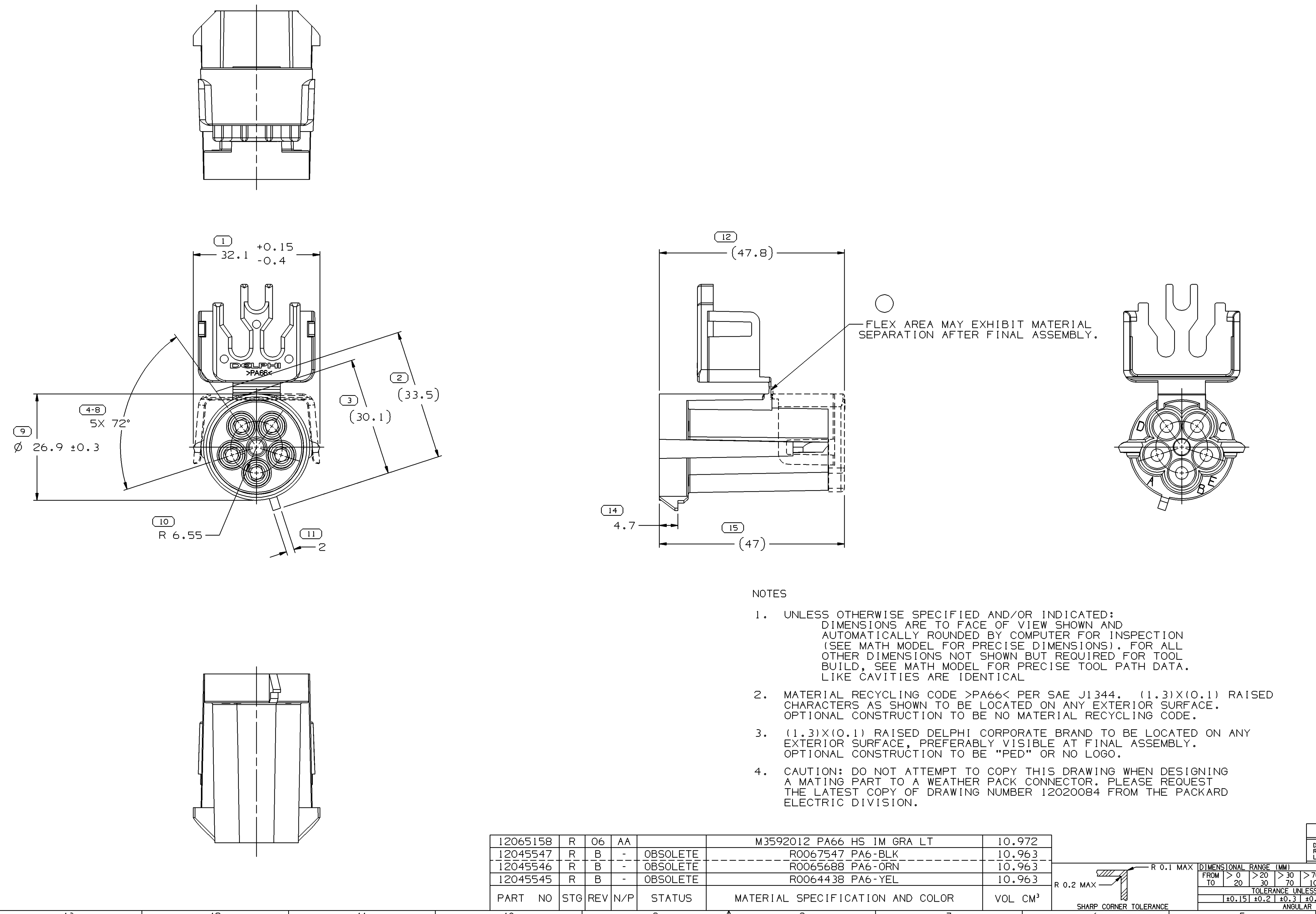
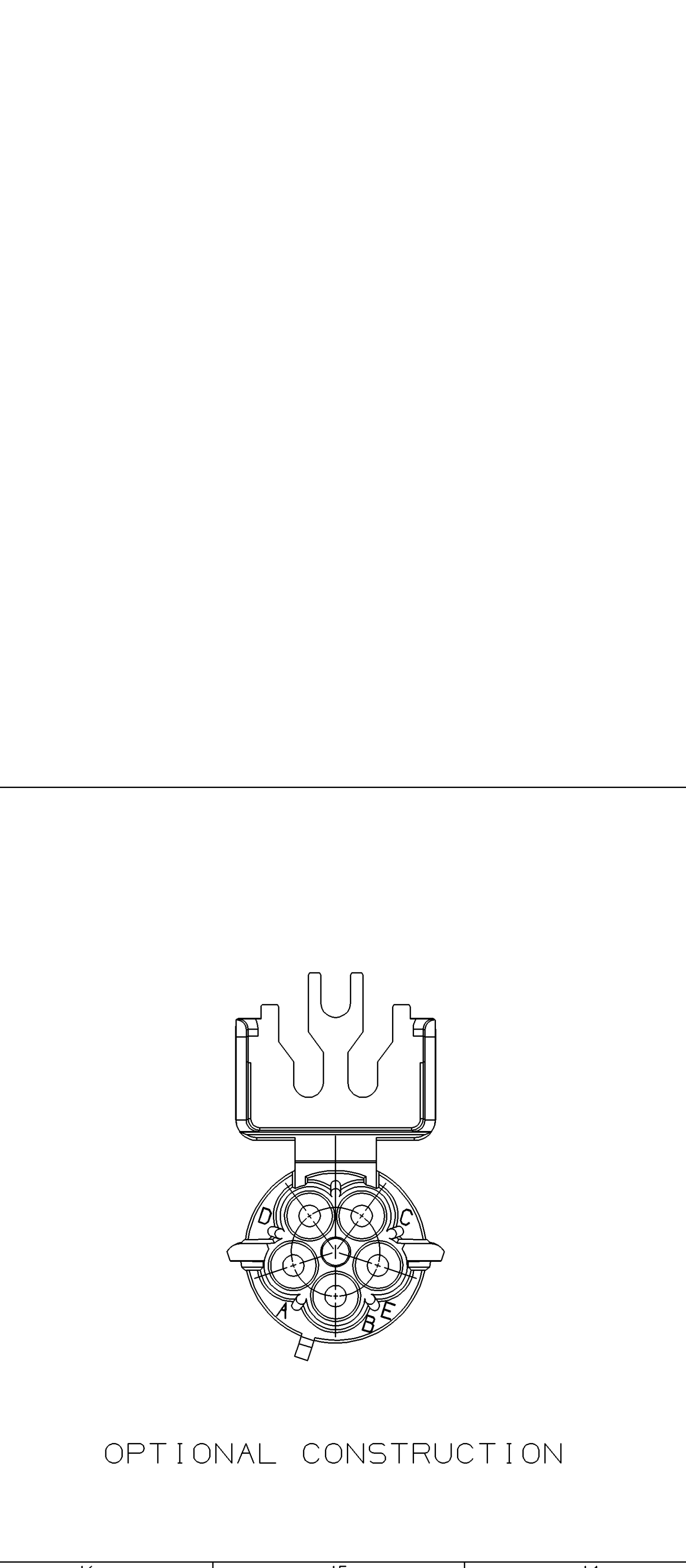

- NOTES
- UNLESS OTHERWISE SPECIFIED AND/OR INDICATED: DIMENSIONS ARE TO FACE OF VIEW SHOWN AND AUTOMATICALLY ROUNDED BY COMPUTER FOR INSPECTION (SEE MATH MODEL FOR PRECISE DIMENSIONS). FOR ALL OTHER DIMENSIONS NOT SHOWN BUT REQUIRED FOR TOOL BUILD, SEE MATH MODEL FOR PRECISE TOOL PATH DATA. LIKE CAVITIES ARE IDENTICAL.
  - MATERIAL RECYCLING CODE >PA66< PER SAE J1344. (1.3)X(0.1) RAISED CHARACTERS AS SHOWN TO BE LOCATED ON ANY EXTERIOR SURFACE. OPTIONAL CONSTRUCTION TO BE NO MATERIAL RECYCLING CODE.
  - (1.3)X(0.1) RAISED DELPHI CORPORATE BRAND TO BE LOCATED ON ANY EXTERIOR SURFACE, PREFERABLY VISIBLE AT FINAL ASSEMBLY. OPTIONAL CONSTRUCTION TO BE "PED" OR NO LOGO.
  - CAUTION: DO NOT ATTEMPT TO COPY THIS DRAWING WHEN DESIGNING A MATING PART TO A WEATHER PACK CONNECTOR. PLEASE REQUEST THE LATEST COPY OF DRAWING NUMBER 12020084 FROM THE PACKARD ELECTRIC DIVISION.

PART NO	STG	REV	N/P	STATUS	MATERIAL SPECIFICATION AND COLOR	VOL CM <sup>3</sup>
12065158	R	06	AA		M3592012 PA66 HS 1M GRA LT	10.972
12045547	R	B	-	OBSOLETE	RO067547 PA6-BLK	10.963
12045546	R	B	-	OBSOLETE	RO065688 PA6-ORN	10.963
12045545	R	B	-	OBSOLETE	RO064438 PA6-YEL	10.963

9 PROCESS SENSITIVE DIMENSION

DIMENSIONS ENCLOSED IN ( ) INDICATE REFERENCE DIMENSIONS AND NO TOLERANCE LIMITS ARE ESTABLISHED

FROM	TO	TOLERANCE
>0	>20	±0.15
>20	>30	±0.2
>30	>70	±0.3
>70	>100	±0.4
>100	>150	±0.5
>150	>200	±0.6
>200	>250	±0.8
>250	>300	±1
>300	>400	±1.2

CHART ET

THIRD ANGLE PROJECTION

DO NOT SCALE

USE MATH DATA

UNSPRINGS

**DELPHI**

DELPHI PACKARD ELECTRIC SYSTEMS  
WARREN, OH

DR	DATE
APVD1 G. ESTRADA	05JA00
APVD2 G. MACIAS	13AFO0
APVD3 Q. GALLEGOS	17AFO0
APVD4	
APVD5	

SUBSTANCES OF CONCERN AND RECYCLED CONTENT PER DELPHI 10949001

MATERIAL SEC CHART

DRAWING NAME: TAXI CONN 5 M W/P SHD N/A

DRAWING NUMBER: 12045548

SIZE A0 SCALE 2:1 FRAME NO 1 OF 1 SHEET NO 1 OF 1 STG REV N/P R 08