

SEE DETAIL A

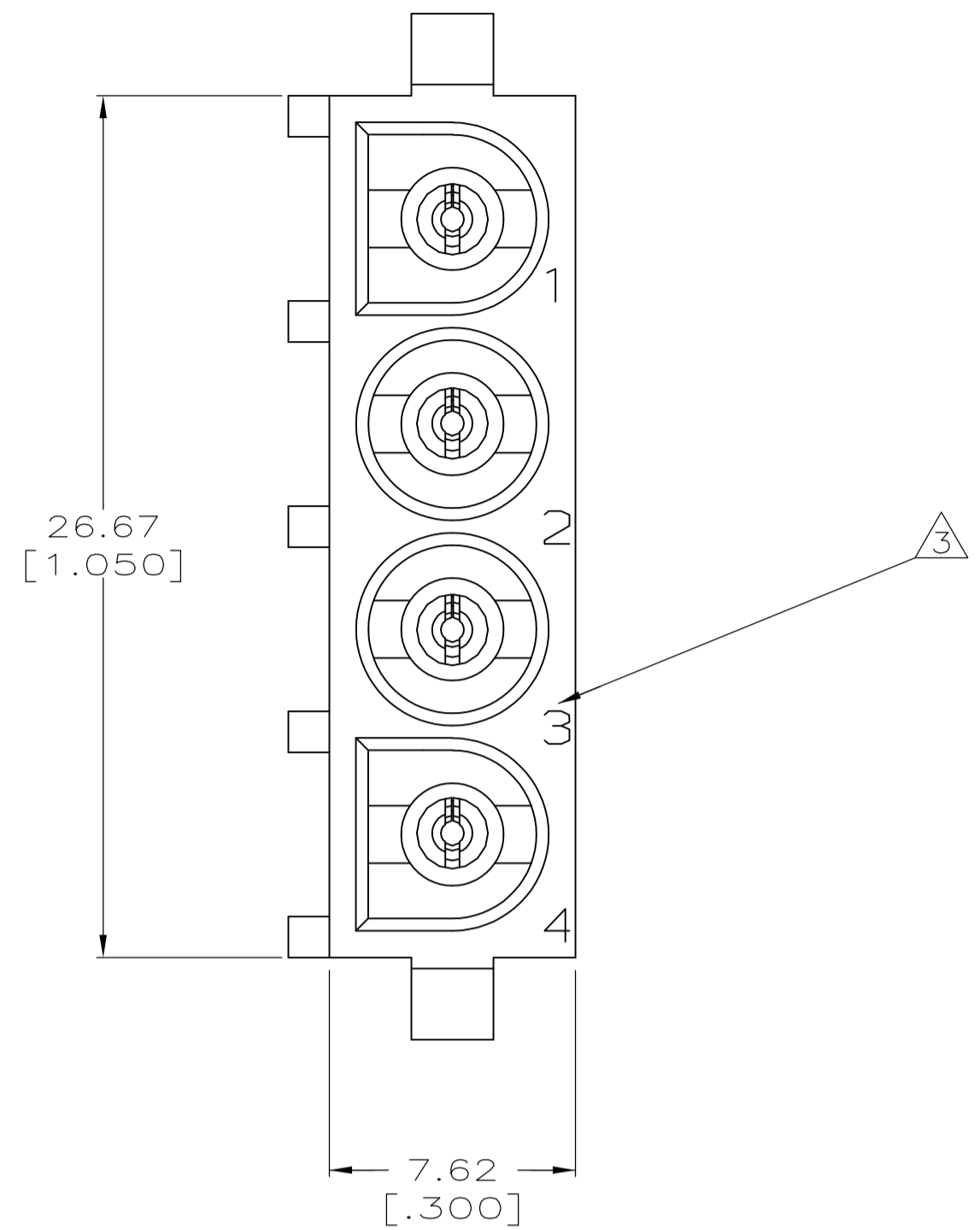

- 1 PARTS COMPLY TO AMP SOLDERABILITY SPECIFICATION 109-11-3.
- 2 CONTACT IS PLATED OVERALL WITH 0.00127 [.000050] NICKEL, THEN 0.00076 [.000030] GOLD OVER CONTACT LENGTH INDICATED AND MATTE TIN LEAD ON SOLDER TAIL END.
- 3 CIRCUIT IDENTIFICATION CHARACTERS ARE ADJACENT TO THE INDICATED CAVITIES, BUT LOCATION AND ORIENTATION MAY DIFFER FROM PRINT.
- 4 DIMENSIONS IN BRACKETS ARE IN INCHES.
- 5 DRAIN HOLES LOCATED AS SHOWN. OPTIONAL CONSTRUCTION - ALL DRAIN HOLES LOCATED 90° AS SHOWN IN DETAIL A.
- 6 CONTACT IS PLATED OVERALL WITH 0.00127 [.000050] NICKEL, THEN 0.00076 [.000030] GOLD OVER CONTACT LENGTH INDICATED AND MATTE TIN ON SOLDER TAIL END.
- 7 SUPERSEDED BY 350792-3

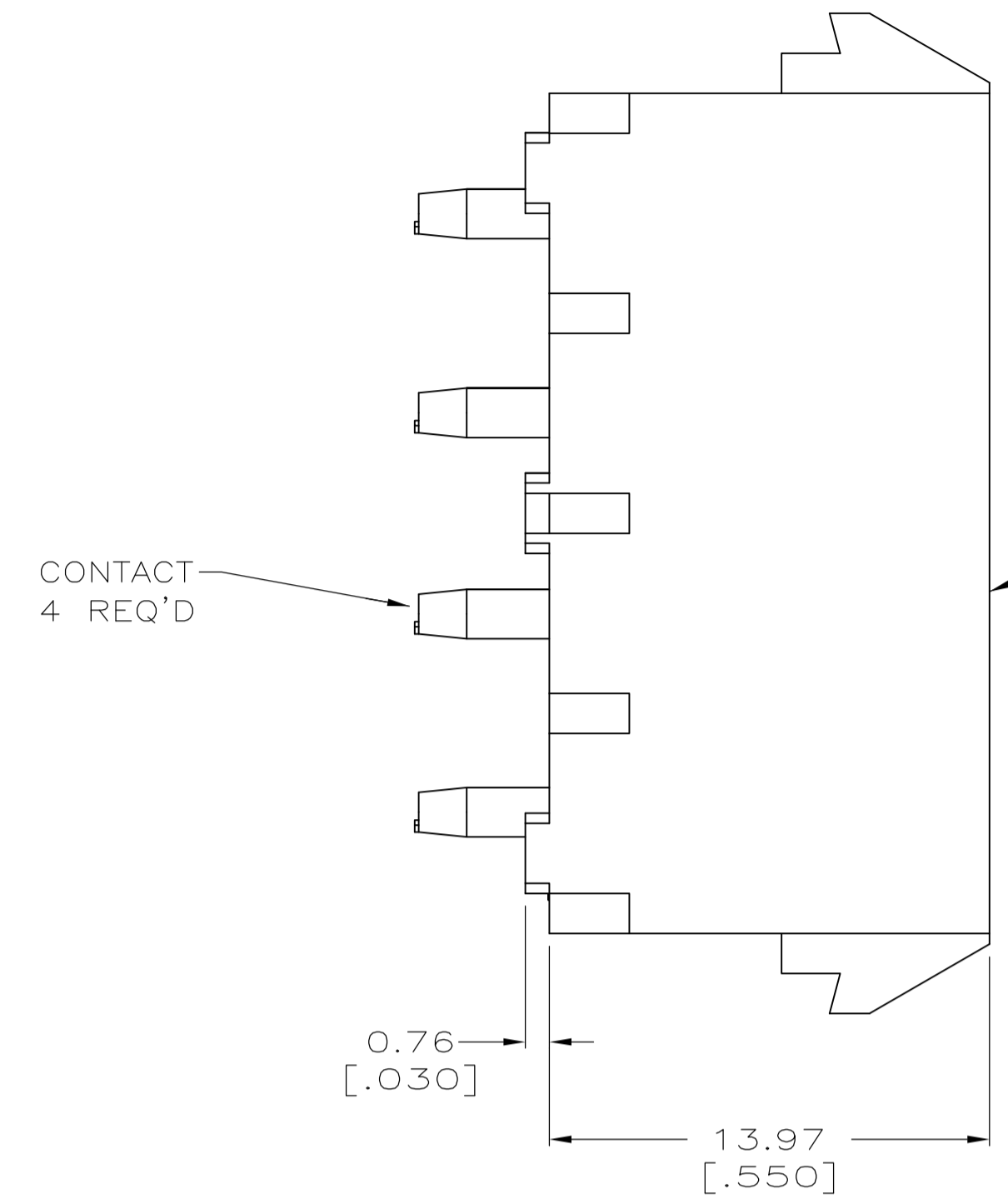
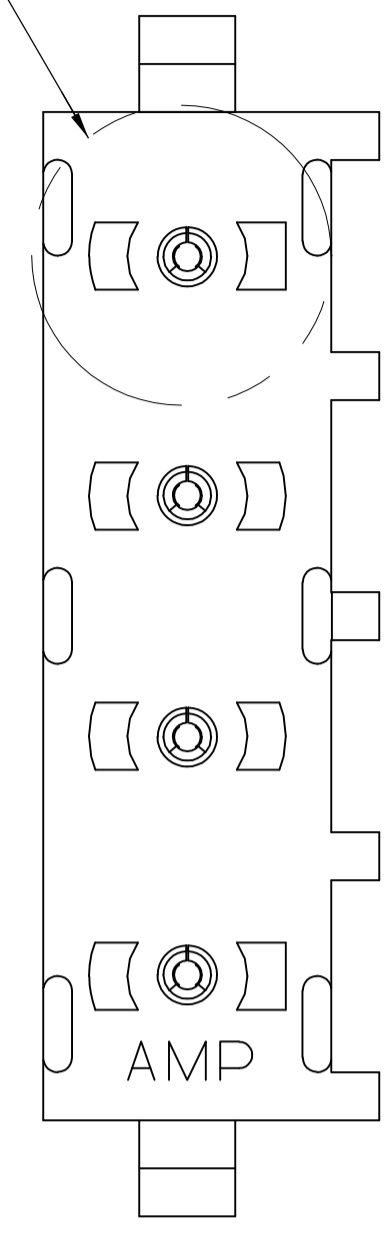
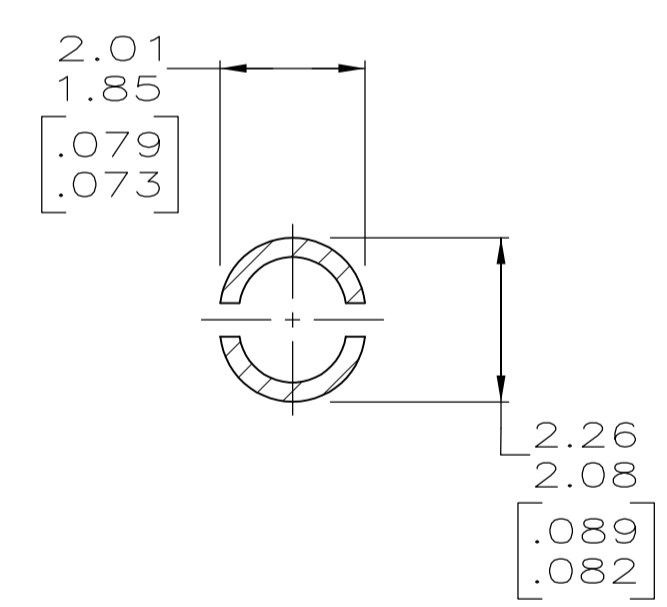
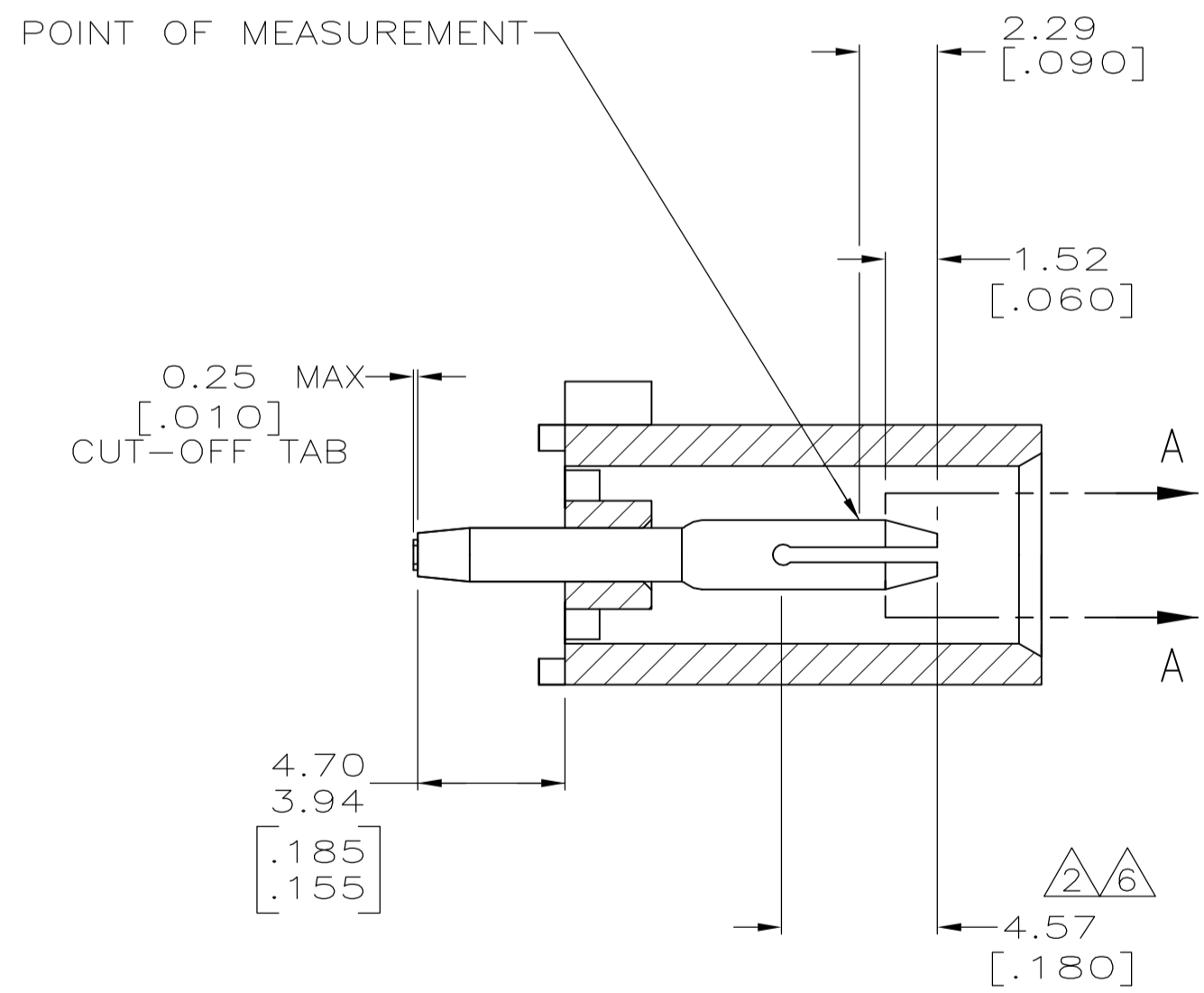

SECTION A-A
SCALE 10:1

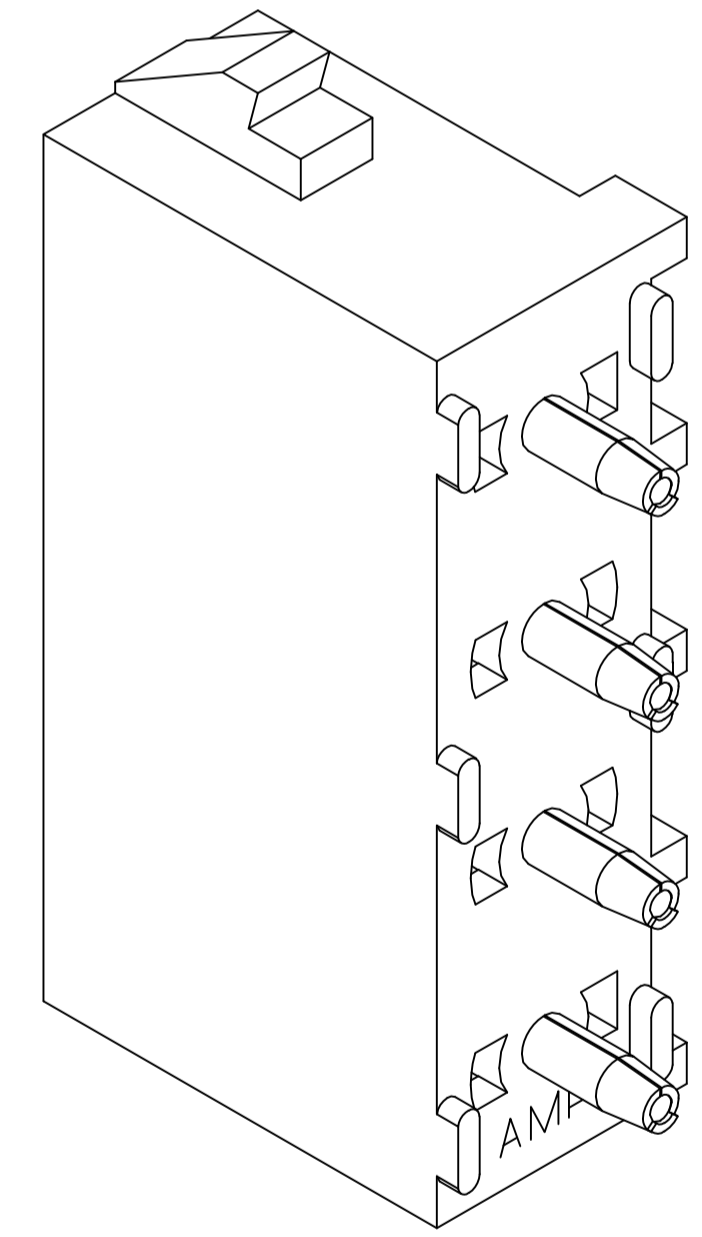

3-DIMENSIONAL MODEL
NTS

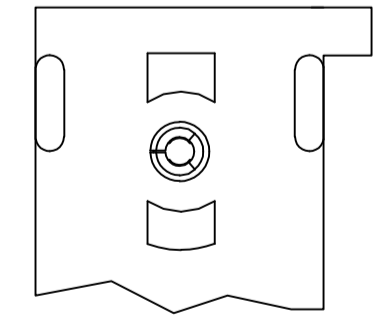

DETAIL A
OPTIONAL CONSTRUCTION

5

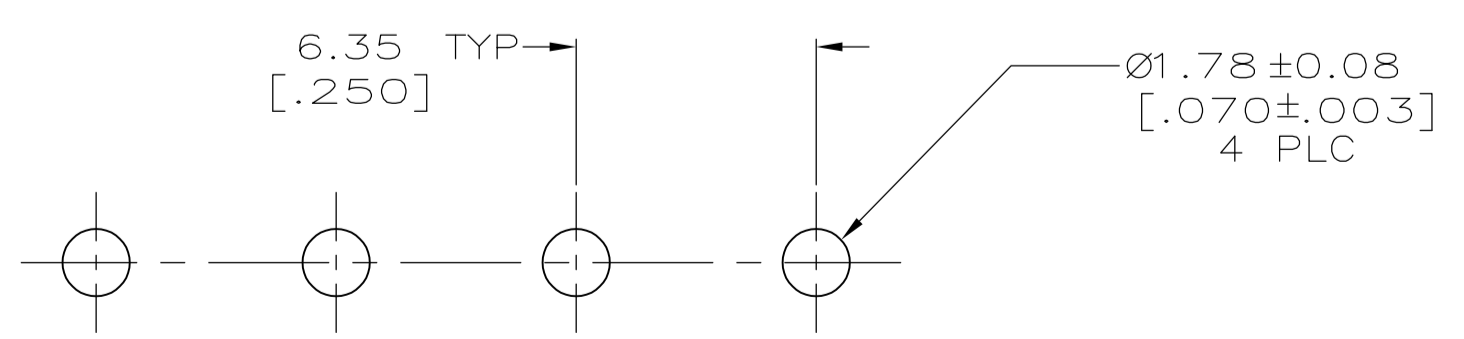

RECOMMENDED MOUNTING HOLE PATTERN
FOR 1.52 [.062] THICK P.C. BOARD

PHOSPHOR BRONZE, GOLD	NYLON,UL94V-0,WHITE	350792-3
PHOSPHOR BRONZE, GOLD	NYLON,UL94V-0,WHITE	350792-2
PHOSPHOR BRONZE, PRE-TIN	NYLON,UL94V-0,WHITE	350792-1
PIN CONTACT AND FINISH	HOUSING MATERIAL	PART NUMBER

THIS DRAWING IS A CONTROLLED DOCUMENT.		DIN 9137	10-05-98	STE TE Connectivity	
DIMENSIONS: mm [INCHES]		0 PLC ± -	1 PLC ± -	NAME: PIN HEADER ASSEMBLY, 4 CIRCUIT UNIVERSAL MATE-N-LOK™	
TOLERANCES UNLESS OTHERWISE SPECIFIED:		2 PLC ± 0.13 [.005]	3 PLC ± -	APPLICATION SPEC	
		4 PLC ± -	ANGLES ± ± 0° 30'	SIZE: A1	
MATERIAL: SEE TABLE	FINISH: SEE TABLE	WEIGHT: -	APPROVED: 00779	CAGE CODE: 350792	RESTRICTED TO: -
CUSTOMER DRAWING			SCALE: 5:1	SHEET: 1 OF 1	REV: R2