

REVISIONS					
P	LTR	DESCRIPTION	DATE	DWN	APVD
	K1	REDRAWN PER ECO-17-007400	05DEC2017	RS	DR

AMP WIRE RANGE	Listed FILE E13288	LR7189 Certified
12-10 AWG SOLID OR STRANDED	12-10 AWG SOLID OR STRANDED	12-10 AWG SOLID OR STRANDED

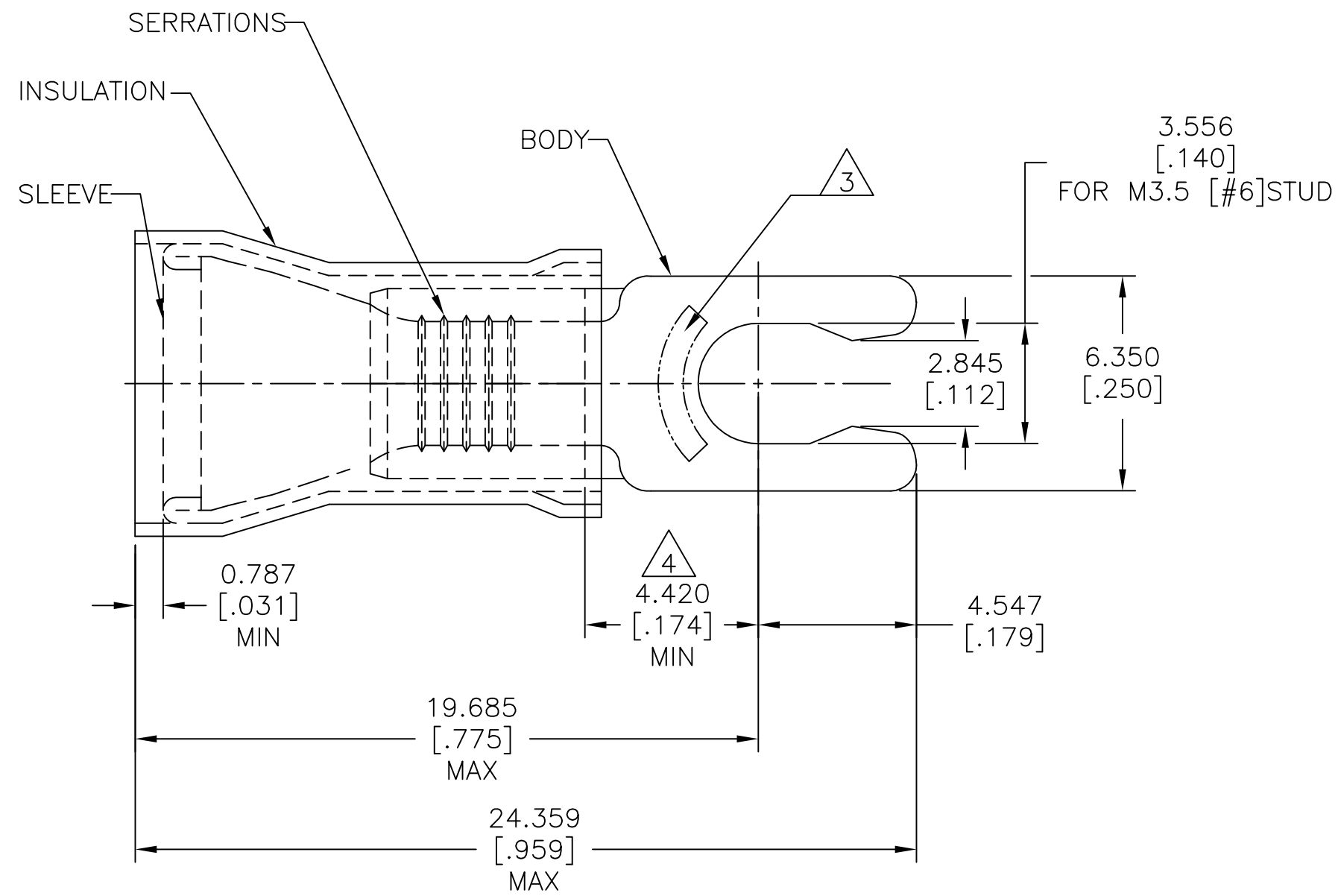

- 1 FOR $\phi 3.810[\phi.150]$ TO $\phi 6.350[\phi.250]$ WIRE INS.
- 2 BODY MATERIAL THICKNESS: $0.991 \pm 0.051[.039 \pm .002]$
- STAMP 6S AMP 12-10* APPROX AS SHOWN.
- APPLIES FROM EDGE OF METAL WIRE BARREL TO CENTER OF STUD HOLE.
- MATERIAL:
 BODY - PHOSPHOR BRONZE PER ASTM B103
 SLEEVE - COPPER PER ASTM B152
 INSULATION - NYLON.
- FINISH:
 BODY & SLEEVE - TIN PLATE PER ASTM B545
 INSULATION - COLOR - YELLOW

2500	ON TAPE, REEL	52941-1
500	LOOSE PIECE	52941
QTY.	PACKAGE TYPE	PART NUMBER

AMP INCORPORATED CUSTOMER SERVICE SYSTEMS		MAX RECOMMENDED OPERATING TEMPERATURE: 105°C [221°F]	THIS DRAWING IS A CONTROLLED DOCUMENT.		DWN RAVI S 05DEC2017	TE Connectivity				
FOR ADDITIONAL PRODUCT INFORMATION OR COPIES OF DRAWINGS AND TECHNICAL DOCUMENTS	PRODUCT INFORMATION CENTER 1-800-522-6752	VOLTAGE RATING: 300 V MAX	DIMENSIONS: mm [INCHES]	TOLERANCES UNLESS OTHERWISE SPECIFIED:	CHK ROHDE DANIEL F 05DEC2017					NAME TERMINAL, PIDG, SPRING SPADE, 12-10
FOR APPLICATION TOOLING INFORMATION	TOOLING ASSISTANCE CENTER 1-800-722-1111	CIRCULAR MIL AREA: 2.62-6.64mm² [5,180-13,100] SOLID OR STRANDED		0 PLC ± - 1 PLC ± - 2 PLC ± - 3 PLC ± 0.127[.005] 4 PLC ± - ANGLES ± -	APVD ROHDE DANIEL F 05DEC2017	PRODUCT SPEC UL 486 A-B	SIZE	CAGE CODE	DRAWING NO	RESTRICTED TO
FOR ORDER ENTRY	1-800-526-5142	THIS DRAWING IS A CONTROLLED DOCUMENT FOR AMP INCORPORATED. IT IS SUBJECT TO CHANGE AND THE CONTROLLING ENGINEERING ORGANIZATION SHOULD BE CONTACTED FOR THE LATEST REVISION.	MATERIAL 	FINISH 	APPLICATION SPEC 114-2157	WEIGHT -	A3	00779	C=52941	-
CUSTOMER DRAWING						SCALE 8:1	SHEET 1 OF 1	REV K1		