

2150A, 2151A, 2112A, 2152A and 2194A Series Non-Relampable Neon-Incandescent Indicator Lights

Description and Features

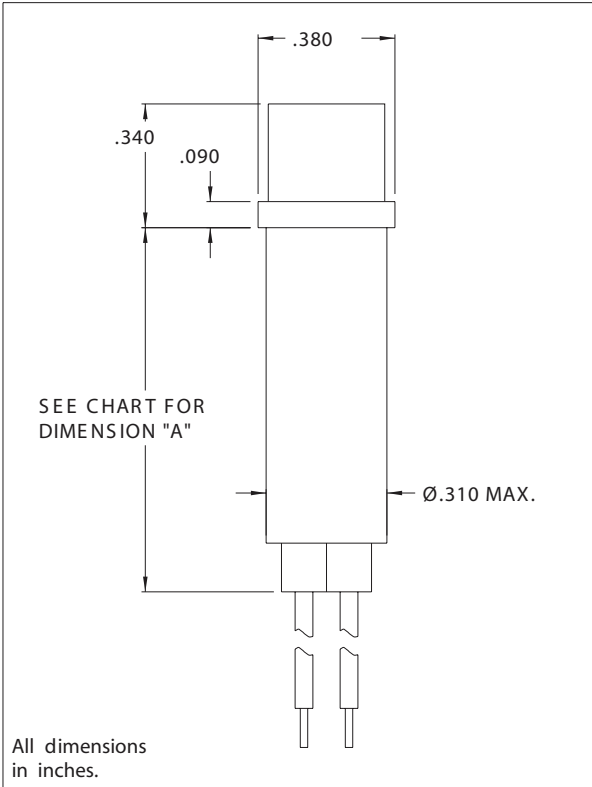

Mounting: Ø.310 MIN., supplied with push-on speednut SN1287.

Wire Leads: No. 22 AWG (105°C), 4.40/4.80 long, stripped .430/.570.

Lens: Polycarbonate-neon transparent, incandescent-translucent

Bezel: Polished stainless steel.

Housing: White Nylon

Lens Color	Neon		Incandescent	
	Model No. (105-125VAC)	Model No. (208-250VAC)	Model No. (12V)	Model No. (28V)
Red	2150A1	2151A1	2194A1-12V	2194A1-28V
Clear	2150A2	-	-	-
Amber	2150A3	2151A3	2194A3-12V	2194A3-28V
White	2150A4	2151A4	-	2194A4-28V
Green	2152A5*	2153A5*	2194A5-12V	2194A5-28V
Blue	2152A6**	2153A6**	-	-
Lamp used	C2A+Resistor	C2A+Resistor	#2162	#2187
Lead Color	Black	Black/Red	Yellow	Purple
"A" DIM	1.310	1.310	.830	.830

* Incorporates G2B lamp and resistor.

** Incorporates T2B lamp and resistor.

Underwriters Laboratories (UL) File No. E20356

Lake-View Electronics Corp. 1054 Pioneer Rd. Grafton, WI Ph: 262-377-8250 Fax: 262-375-0109

www.lvelectronics.com

Email: sales@lvelectronics.com