

Features

- Automotive applications
- Standardized terminal size & layout
- Now with continuous current capacity to 80 amps !
- Plastic cover for enviromental protection

Characteristics

- Operate / Release Time: 7ms / 2 ms typical
- Dielectric Strength: 500 Vrms, 1 minute
- Insulation Resistance: 100M @ 500 VDC, 50% RH
- Shock Resistance: 20g, 11ms
- Vibration Resistance: 10-40Hz, 1.27mm DA
40-70Hz, 5g
70-100Hz, 0.5mm DA
100-500Hz, 10g
- Drop Resistance: 1M drop (6 axii) to concrete in final enclosure (GM)
- Power Consumption: 1.6W, un-suppressed ; 1.81W w/68 resistor
- Ambient temperature: -40 C to +125 C operating
-40 C to +155 C storage
- Weight: 31g, approx.



Typical Applications :Head Lights, Fog Lamps
Blower Control, Horn,
Power Windows, Fans,
Starters, ABS Systems

Contact Data

Model	G4130	G4160	G4180
Contact Arrangement	1 Form A ; 1 Form C	1 Form A ; 1 Form C	1 Form A; 1 Form C
Max. Switching Current (M/B)	Form A: 120A/40A Form C: NC45A, NO120A	Form A: 120A/60A Form C: NC45A, NO120A	Form A : 240A/80A Form C: NO240A/NC180A
Contact Material	AgNi	AgCdO	AgSnInO
Max. Switching V	See Curve #1, Current Dependent	See Curve #1, Current Dependent	See Curve #2, Current Dependent
Max. Continuous Current	Form A: 30A Form C: NO30A/ NC30A	Form A: 60A Form C: NO60A/ NC40A	Form A : 80A Form C : NO 80A / NC 60A
Minimum Load (reference)	0.1A, 12VDC	0.5A, 12VDC	0.5A, 12VDC
Mechanical Life	10,000,000 ops.	10,000,000 ops.	10,000,000 ops.
Electrical Life	200,000 ops. (See Note 4)	200,000 ops. (See Note 4)	200,000 ops. (See Note 4)

Coil Data

Nominal Voltage	Coil Resistance 10%	Pull-In Voltage	Drop-Out Voltage
6	22	3.6	0.6
12	90	7.2	1.2
24	330	14.3	2.4

Useful Curves

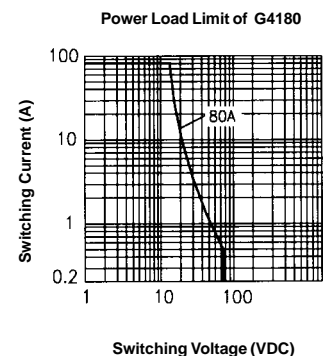
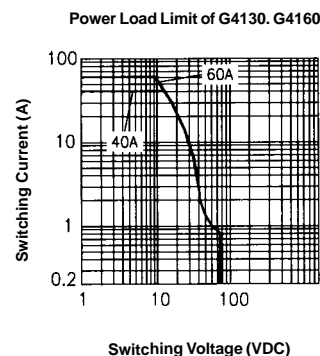

■ Overall Dimensions, Optional Covers, Terminal Layouts, Mounting Holes, and Wiring Diagrams (mm)

Plug-in Type

G4130, G4160

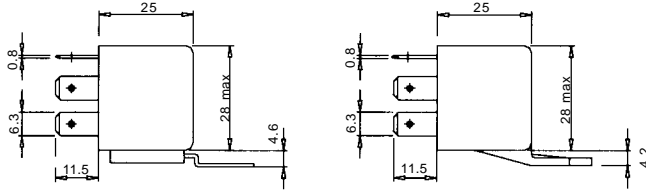

G4180

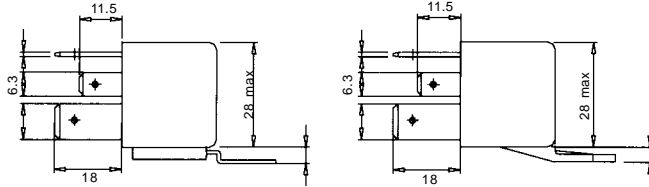

1 Form A

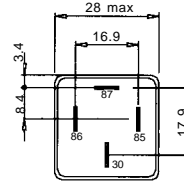

1 Form A (AA)
1 Form C

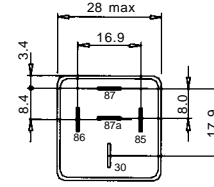

1 Form A

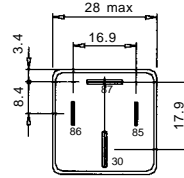

1 Form C

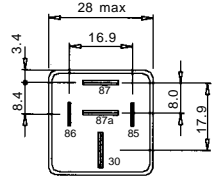

Optional Covers

Molded Bracket

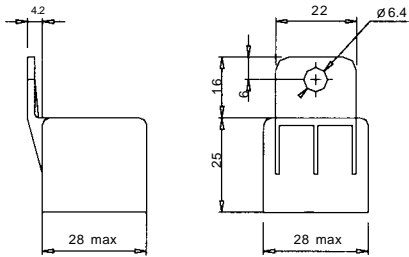

Skirted Cover w/Metal Bracket
Skirted Cover w/Bent Metal Bracket

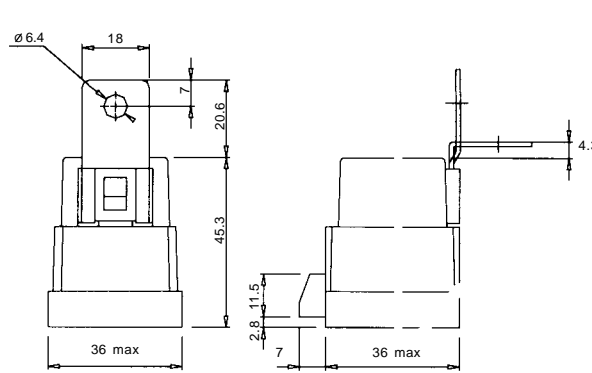

Metal Bracket
Bent Metal Bracket

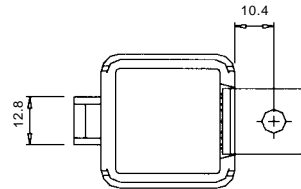
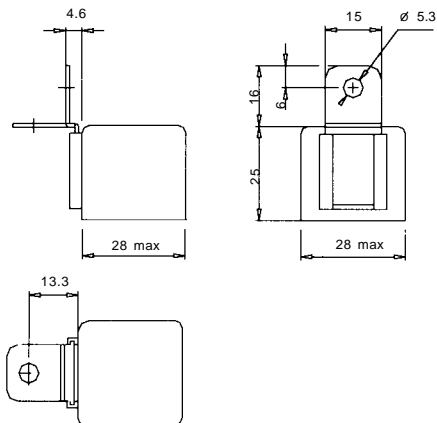

Overall Dimensions, PCB Type

G4130, G4160

G4180

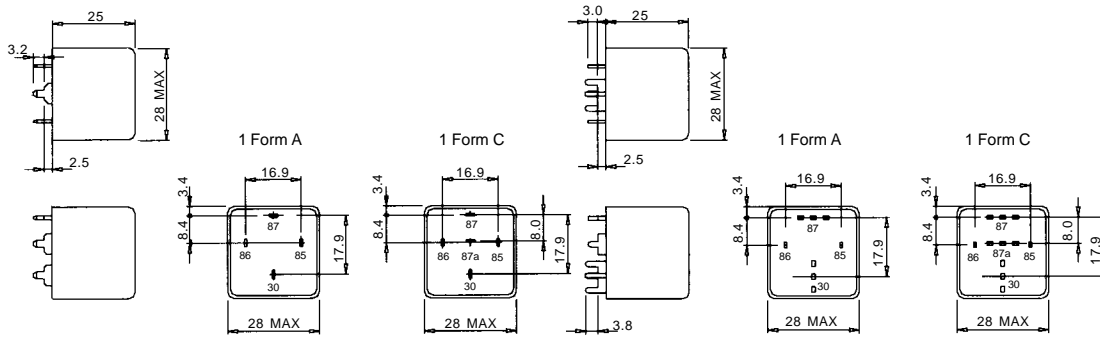

PCB Type Mounting Holes (Bottom View)

G4130, G4160

G4180

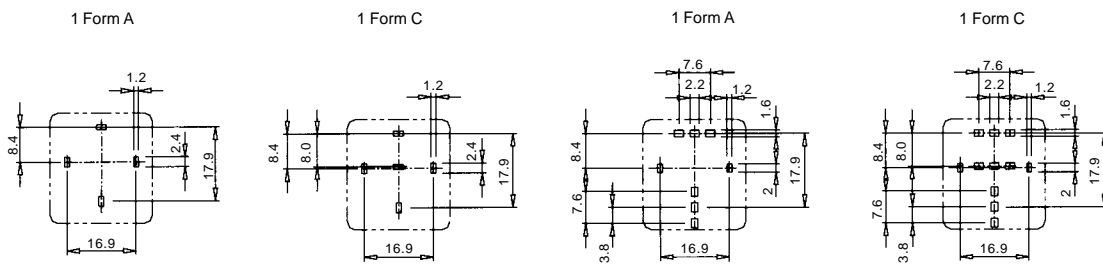

Wiring Diagrams

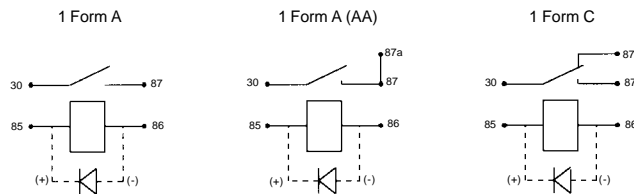

- Notes: 1) All parameters, unless otherwise specified, are measured at ambient temperature of 23°C
 2) Maximum make current refers to inrush current of lamp load.
 3) At ambient temperature of 85 C, maximum allowable voltage should be reduced to 72%.
 4) Electrical life obtained at resistive or inductive load at 20A,15VDC for G4130; 40A, 15VDC for G4160; 80A, 15VDC for G4180 (with suitable arc-suppression circuit attached with operating frequency of 1 ops/sec.)
 5) Specifications subject to change without prior notice.

How to Order

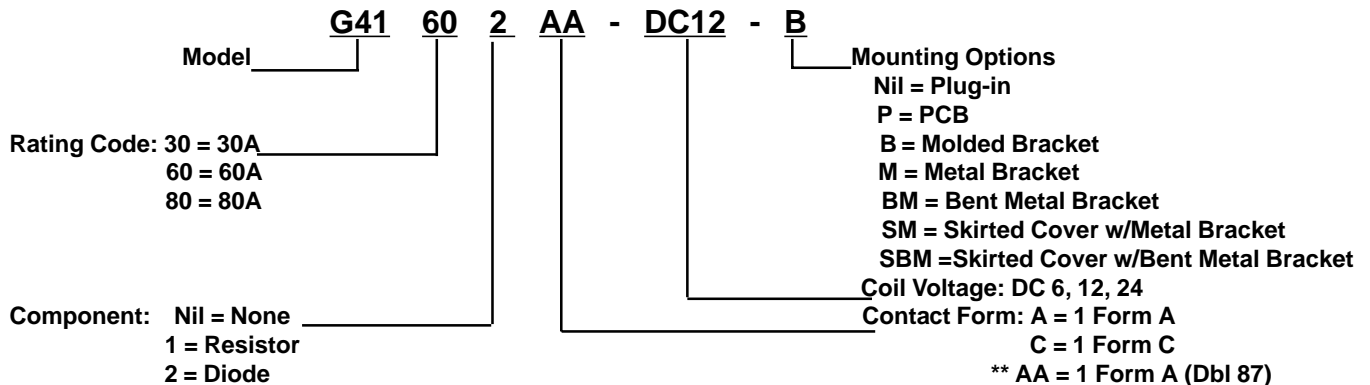

** G4130 and G4160 only