

ELECTRO-ACOUSTIC TRANSDUCER

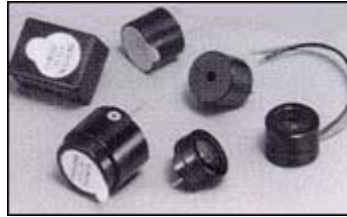

ROHS COMPLIANT UPON REQUEST

PART NUMBER:
BST1811P-06

SPECIFICATIONS:

RATED VOLTAGE:	6 VDC
OPERATING VOLTAGE:	3 ~ 10
MAX CURRENT:	40 mA
SOUND OUTPUT LEVEL:	85dB @ 10 cm
TERMINAL TYPE:	2 PINS
RESONANT FREQUENCY:	2000-2500
OPERATING TEMPERATURE:	-30 TO +85°C
TONE MODE:	CONTINUOUS
PULSE RATE:	N/A
COIL RESISTANCE:	60 ± 9
COIL IMPEDANCE:	90
FRAME DIAMETER:	18 x 14 mm
FRAME DEPTH:	11.0 mm
MOUNTING DIMENSIONS:	6.5 mm

COMMENTS:

*VALUE APPLYING RATED VOLTAGE (RESONANT FREQUENCY,

**VALUE APPLYING (RESONANT FREQUENCY, SINE WAVE, M

DIMENSIONS:

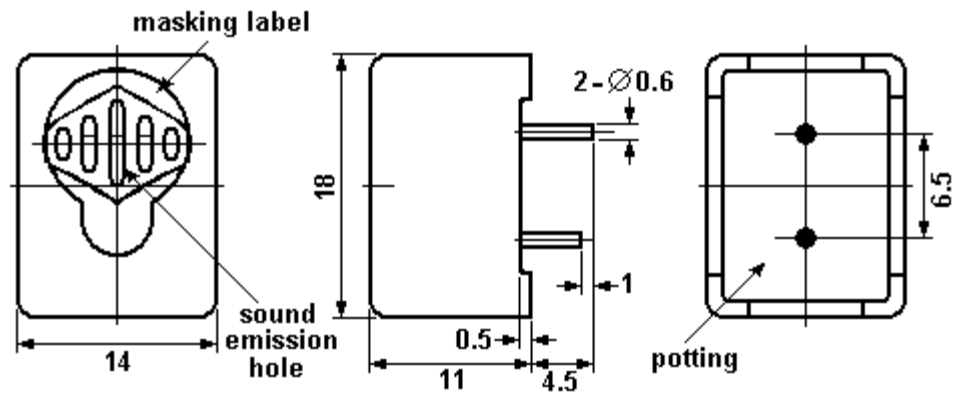

Lake-View Electronics Corp. 1054 Pioneer Rd. Grafton, WI Ph: 262-377-8250 Fax: 262-375-0109

www.lvelectronics.com

Email: sales@lvelectronics.com