

## SUBMINIATURE TYPE

### 922, 923, 924 Series Incandescent Lampholders



The mating lens caps accept a T-1<sup>3/4</sup> midget flanged base incandescent lamp, held in the lens assembly by means of a friction fit which insures good contact and prevents the lamp from falling out when the lens is removed. A lens assembly must be used with the holder to hold the lamp in proper relationship to the socket contact.

**APPROVALS:** Recognized under the Components Program of Underwriters Laboratories and Certified by CSA.

**SPECIFICATIONS:**

**Housing:** Brass. Black nickel finish. White nickel or chrome finish optional.

**Internal Tooth Lockwasher:** Phosphor bronze. White nickel finish.

**Hex Nut:** Brass. 922 and 923 Series: White nickel finish. 924 Series: Same finish as housing finish.

**Terminals:** Brass. Tin-plated with elongated slot (3/64" x 3/32"). Tapered to accept a quick-connect receptacle. Center contact marked +.

**Socket:** Brass. White nickel-plated.

**Lens:** Molded plastic. (-55°C to +75°C)

**Lens Marking:** Flat rotatable lenses may be stamped. Contact factory.

**Lens Barrel:** Brass. White nickel-plated.

**Lens Retainer:** Brass. Black nickel finish. White nickel or chrome finish - optional.

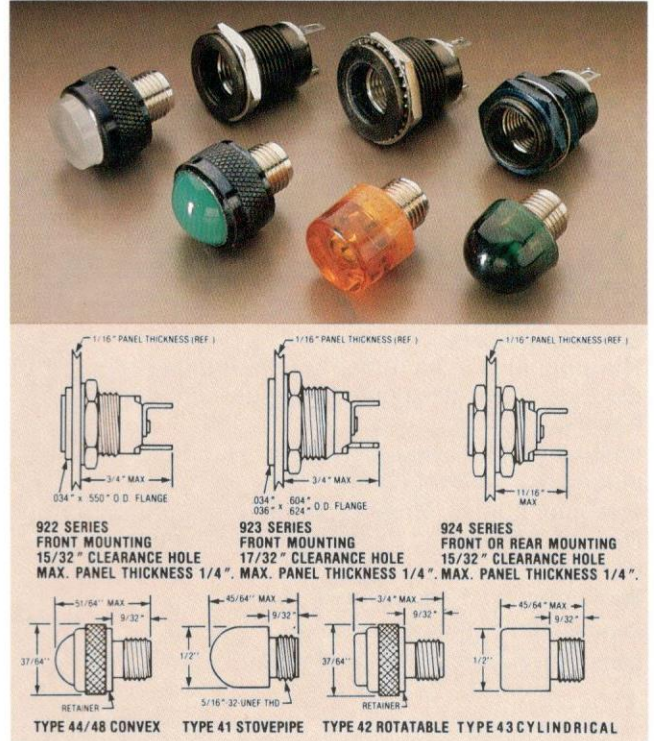

**ORDERING INFORMATION:**

Lampholders and lens caps may be ordered separately or as complete assemblies as shown in the example below:

**EXAMPLE (Complete Assembly):** 922 - 4 0 4 X - 42 4 BN

Lampholder Only      Lens Cap Only

Black Nickel Finish

Flat Rotatable Lens

Black Nickel Retainer

Blue Nondiffusing Lens

Lampholders					Lens Cap Assembly		
Series	Termination	Features	Finish	Resistor	Lens Style	Retainer	Lens Colors
922	4 Solder Lug Terminals	0 None	4 Black Nickel (standard)	X None	41 Stovepipe	0 <sup>2</sup> No Retainer	NONDIFFUSING (Clear)
					42 <sup>1</sup> Flat Rotatable	4 Black Nickel Finish (standard)	
923			5 White Nickel		43 Cylindrical	5 Bright Nickel Finish	AN Amber
					44 Convex—Nondiffusing Colors Only	7 Chrome Finish	BN Blue
924			7 Chrome		48 Convex—Diffusing Colors Only		CN Colorless
							GN Green
							RT Red
							WN White (Cloudy)
							YN Yellow
							<b>TRANSLUCENT</b>
							AT Amber
							BT Blue
							GT Green
							RT Red
							WT White
							YT Yellow
							<b>DIFFUSING</b>
							AD Amber
							BD Blue
							CD Colorless
							GD Green
							RD Red
							YD Yellow

<sup>1</sup> Lens Marking Available. Contact factory.  
<sup>2</sup> Lens types 41 and 43 do not require retainer.