

Specifications:

Sound level Category	Medium Sound Level
Mode of Operation	Fast Pulse
Mounting	Panel (see note B)
Voltage Rating	6 to 28 Vac/dc
Frequency	2900 Hz ±500 Hz
Loudness (Min. Voltage)	68 dB(A) min. @ 2 FT and 6 Vac/dc
Loudness (Max Voltage)	80 dB(A) min. @ 2FT and 28 Vac/dc
Min. Pulse Rate (PPS)	2 @ 10 Vac/dc
Max. Pulse Rate (PPS)	10 @ 48 Vac/dc
Duty Cycle (%)	50 (Approx)
Current Draw	4 mA Max @ 6 Vac/dc
Current Draw	16 mA Max @ 28 Vac/dc
Storage Temperature	-40°C to +85°C
Operating Temperature	-30°C to +65°C
Weight (Typical)	2.7 oz (76 g)
Housing	6/6 Nylon, Color Black
Options	For other options contact factory

Dimensions: Inches (mm)



PART DIMENSIONS BEFORE CODE DATE 0810 5 PART DIMENSIONS AFTER CODE DATE 0811 1

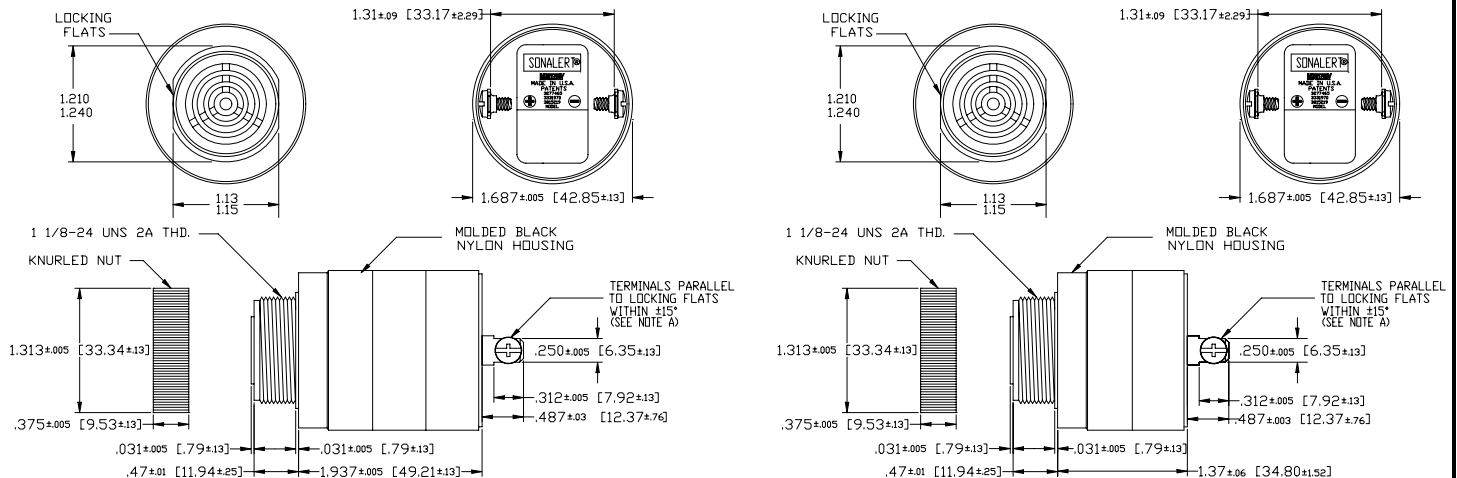

NOTE A: TERMINALS--032 BRASS TIN PLATED, TAPPED FOR #6-32 SCREW. TWO #6-32 NICKEL PLATED BRASS SCREWS INCLUDED. WILL ACCEPT 1/4" QUICK CONNECT.

NOTE B: MOUNTING-- REMOVE BLACK PLASTIC NUT AND INSERT THREADED FRONT THROUGH 1.25" HOLE PUNCHED IN PANEL. IF ORIENTATION IS NEEDED, NOTE LOCKING FLATS ON DRAWING. SCREW NUT BACK ON. DO NOT OVERTIGHTEN.

NOTE A: TERMINALS--032 BRASS TIN PLATED, TAPPED FOR #6-32 SCREW. TWO #6-32 NICKEL PLATED BRASS SCREWS INCLUDED. WILL ACCEPT 1/4" QUICK CONNECT.

NOTE B: MOUNTING-- REMOVE BLACK PLASTIC NUT AND INSERT THREADED FRONT THROUGH 1.25" HOLE PUNCHED IN PANEL. IF ORIENTATION IS NEEDED, NOTE LOCKING FLATS ON DRAWING. SCREW NUT BACK ON. DO NOT OVERTIGHTEN.

Lake-View Electronics Corp. 1054 Pioneer Rd. Grafton, WI Ph: 262-377-8250 Fax: 262-375-0109

www.lvelectronics.com

Email: sales@lvelectronics.com