

Miniature 12 & 20 Amp General Purpose Relay PC113



FEATURES

- 1 and 2 Pole Contact Forms
- 12 & 20 Amp Switching Capacity
- AC & DC Coils Available
- Available as Plug In or PC Pins
- Available with Gold Plated Contacts
- UL Class B Insulation Standards
- Arc Barrier Equipped
- Available with Top Mounting Flange
- Compatible with SC113 Series Sockets
- RoHS Compliant



Load Type	Voltage	1 Form C (SPDT)	2 Form C (DPDT)
General Purpose	277 VAC	20 A	10 A
	250 VAC	20 A	12 A
	28 VDC	20 A	12 A
Motor	125 VAC	1/2 HP	1/2 HP
	250 VAC	1/2 HP	1/2 HP
Max. Switching Power		3750 VA 420 W	3000 VA 336 W

CONTACT DATA

Material		AgCdO (Silver Cadmium Oxide)
Initial Contact Resistance		50 milliohms max @ 0.1 A, 6 VDC
Service Life	Mechanical	1 X 10 ⁷ Operations
	Electrical	1 X 10 ⁵ Operations

CHARACTERISTICS

Operate Time	25 ms Max
Release Time	25 ms Max
Insulation Resistance	1,000 MΩ min (at 500 VDC)
Dielectric Strength	1500 Vrms, 1 min. Between Coil and Contacts
	1000 Vrms, 1 min. Between Open Contacts
	1000 Vrms, 1 min. Between Contacts Poles
Shock Resistance	100 m/s ² 11 ms,
Power Consumption	1 & 2 Pole DC 0.9 W, AC 1.2 VA

CHARACTERISTICS CONTINUED

Vibration Resistance	10 Hz - 55 Hz DA 1.5 mm
Terminal Strength	8N; 4N PC Type
Solderability	235 °C ± 2°C 3 s ± 0.5 s
Pre-Heat	
Operating Temperature	-40 to 70 °C
Relative Humidity	85% (at 30°C)
Weight	37 grams

ORDERING INFORMATION

Example: PC113 -1C -P -C1 -120A -L -X

Model: **PC113**

Contact Form: **1A (1U), 1B or 1C; 2A, 2B or 2C**

Terminal Type: **Nil:** Solder Lugs; **P:** PC Pins

Case Type: **Nil:** Plain Case; **C1:** Flange Mount Case

Coil: **XXXA:** AC Coil; **XXXD:** DC Coil

Options: **Nil:** None; **G:** Gold Plate Contacts; **L:** LED Indicator; **D:** Internal Diode

RoHS Compliant: **-X:** RoHS Compliant

See SC113-2C for Available Plug-In Socket
See SC113-2C-PCB for Available Pin Socket

Note: LED polarity is positive on terminal 8 and negative on terminal 7

Box Quantity: 500; Inner Box: 250

Lake-View Electronics Corp. 1054 Pioneer Rd. Grafton, WI Ph: 262-377-8250 Fax: 262-375-0109

www.lvelectronics.com

Email: sales@lvelectronics.com

COIL DATA

Voltage Type	Coil Voltage		Resistance Ohms ± 10%	Must Operate Voltage Max. (VDC)	Must Release Voltage Min. (VDC)
	Coil Power	Rated			
DC 0.9 W		6	40	4.8	0.6
		12	160	9.6	1.2
		24	650	19.2	2.4
		36	1440	28.8	3.6
		48	2600	38.4	4.8
		110	11000	88.0	11.0
		220	53778	176.0	22.0
AC 1.2 VA		6	11.5	4.8	1.8
		12	46	9.6	3.6
		24	184	19.2	7.2
		36	320	28.8	10.8
		48	735	38.4	14.4
		120	4550	96.0	36.0
		220	14400	176.0	66.0
		240	19000	192.0	72.0

NOTES:

The use of any coil voltage less than the rated voltage will compromise the operation of the relays. Must Operate Voltage is listed for test purposes only and is not to be used as design criteria. Pickup and release voltages are for test purposes only and are not to be used as design criteria. Dimensions are in mm, Inches are listed for reference only.

DIMENSIONS (mm/inches)

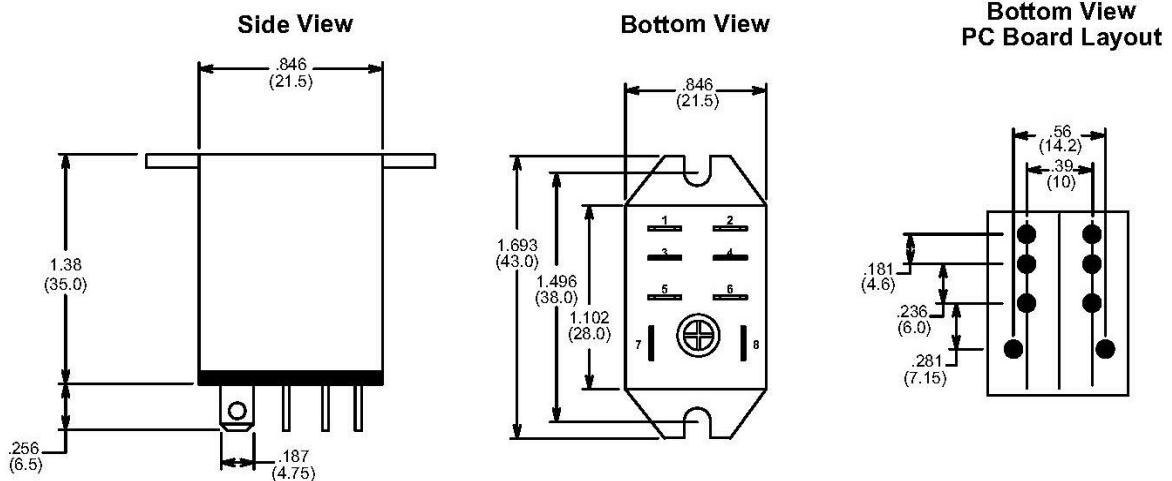

Wiring Diagram 1 Pole

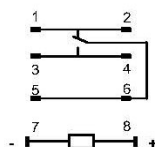

Wiring Diagram 2 Pole

