



VCM-03 Solid-State On-Delay Timer Relay

InPower's VCM Series *Vehicle Control Modules* are a set of tools for the designers of vehicle electrical control systems. Designed to withstand the environments typically found on trucks, emergency vehicles, buses, coaches and speciality vehicles, the modules are available in a variety of standard and custom configurations and functions.

Technical Description

The VCM-03 Series On-Delay Timer is a completely solid-state timer relay with a +12 volt @ 15 amp output. The module's two inputs are activated by a transition to +12 volts (Input A) and by a transition to ground (Input B). The two inputs operate as a logical Exclusive OR so that either input can operate the timer.

The timer will start when +12 volts is applied to Input A while Input B is off, or when ground is applied to Input B while Input A is off. The input must be maintained to operate the timer. If removed before the timer expires, the operation will reset. Activating either input starts the timer. The output turns on when the timer expires, and will remain on until the input is removed. Fixed and adjustable time settings are available. Adjustable time values are set using a single-turn potentiometer. Custom timer values and functions are also available. See the *Ordering Guide* for the standard models and please call us regarding custom models.

Key Features

- 100% Solid-State Construction
- Standard Automotive Relay Pin Format
- 12 Volt 15 Amp Solid-State Output
- Compact Size with Panel-Mount Bracket
- Dual Inputs (Ground and +12 Volt Actuated)
- Durable Metal Case

Ordering Guide

Model	Time Range	Model	Time Range
VCM-03-01SA	0 - 1 Second Adjustable	VCM-03-03MA	0 - 3 Minutes Adjustable
VCM-03-01SF	1 Second Fixed	VCM-03-05MF	5 Minutes Fixed
VCM-03-04SF	4 Seconds Fixed	VCM-03-10MA	0 - 10 Minutes Adjustable
VCM-03-10SA	0 - 10 Seconds Adjustable	VCM-03-10MF	10 Minutes Fixed
VCM-03-60SA	0 - 60 Seconds Adjustable	VCM-03-60MA	0 - 60 Minutes Adjustable

System Diagram

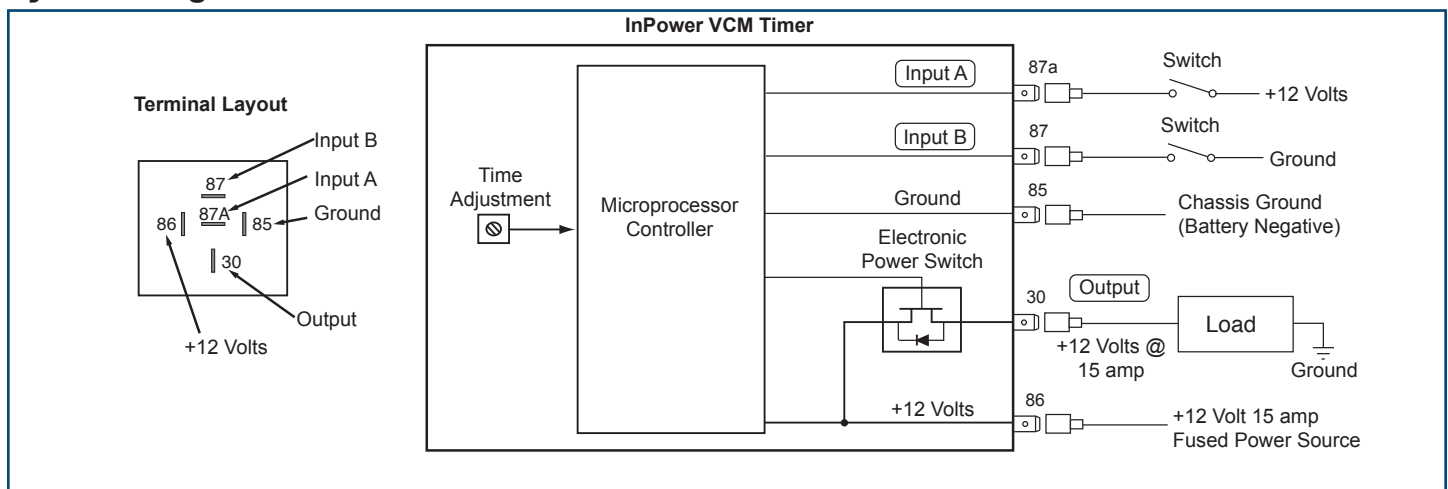

Specifications

Power Input (86):	+8 to +16 Vdc, 15 Amps max.
Ground (85):	Connection to vehicle ground (Battery Negative)
Input A (87a):	On = >4.0 V, Off = <2.5 V
Input B (87):	On = <2.0 V, Off = >3.0 V
Module Output (30):	+12 volts @15 amps, with over current fault shutdown
Mechanical	
Dimensions:	2.30 W x 1.75 H x 1.25 D inches
Case Material:	Anodized aluminum
Operating Temperature:	-40° C to +85° C
Weight:	0.10 lbs.

Timing Diagram

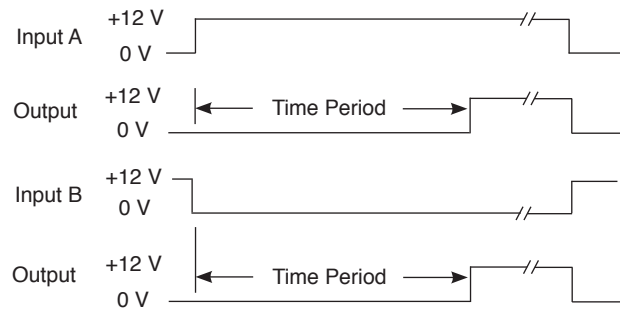

Installation

1. We recommend that the module be installed by a person trained and skilled in vehicle electrical systems. The installation should comply with SAE (Society of Automotive Engineers) and the vehicle manufacturer's electrical wiring procedures (e.g., Ford General Motors, etc.).
2. The module should be installed inside the vehicle in a dry and protected environment.
3. For optimum performance the module should be mounted to a flat metal surface.
4. Do not connect loads to the outputs that will exceed the output current rating of the module.
5. The power input (BAT+ terminal) must be wired to a fused +12 volt battery power source.
6. Wiring must be of the proper gauge and type to handle the intended load currents.
7. Use ¼ inch female blade terminals to connect wires to the terminals on the module. Be sure to properly crimp these terminals. **Do not solder wires directly to the module terminals.**
8. If you are experiencing problems with the installation or need troubleshooting assistance, contact InPower Customer Service at 740-548-0965.

Mechanical Drawing



Lake-View Electronics Corp.
Phone: 1-800-686-8439
Fax: 262-375-0109