



VCM-10 Dual Input Solid-State Power Relay

InPower's VCM Series *Vehicle Control Modules* are a set of tools for the designers of vehicle electrical control systems. Designed to withstand the environments typically found on trucks, emergency vehicles, buses, coaches and speciality vehicles, these modules are available in a variety of standard and custom configurations and functions.

Technical Description

The InPower VCM-1 is a completely solid state relay with a single +12 volt @ 15 amp output. The module has two inputs, one actuated by a transition to +12 volts (Input A) and one actuated by a transition to ground (Input B). The output is actuated when either Input A or Input B is activated. The output is rated at +12 volts @ 15 amps and provides over current and short circuit shut down protection.

Key Features

- 100% Solid-State Construction
- Standard Automotive Relay Pin Format
- 12 Volt 15 Amp Solid-State Output
- Compact Size with Panel-Mount Bracket
- Dual Inputs (Ground and +12 Volt Actuated)
- Durable Metal Case

Ordering Guide

Model	Description
VCM-10	Dual input solid-state relay with +12 volt @ 15 amp output.

System Diagram

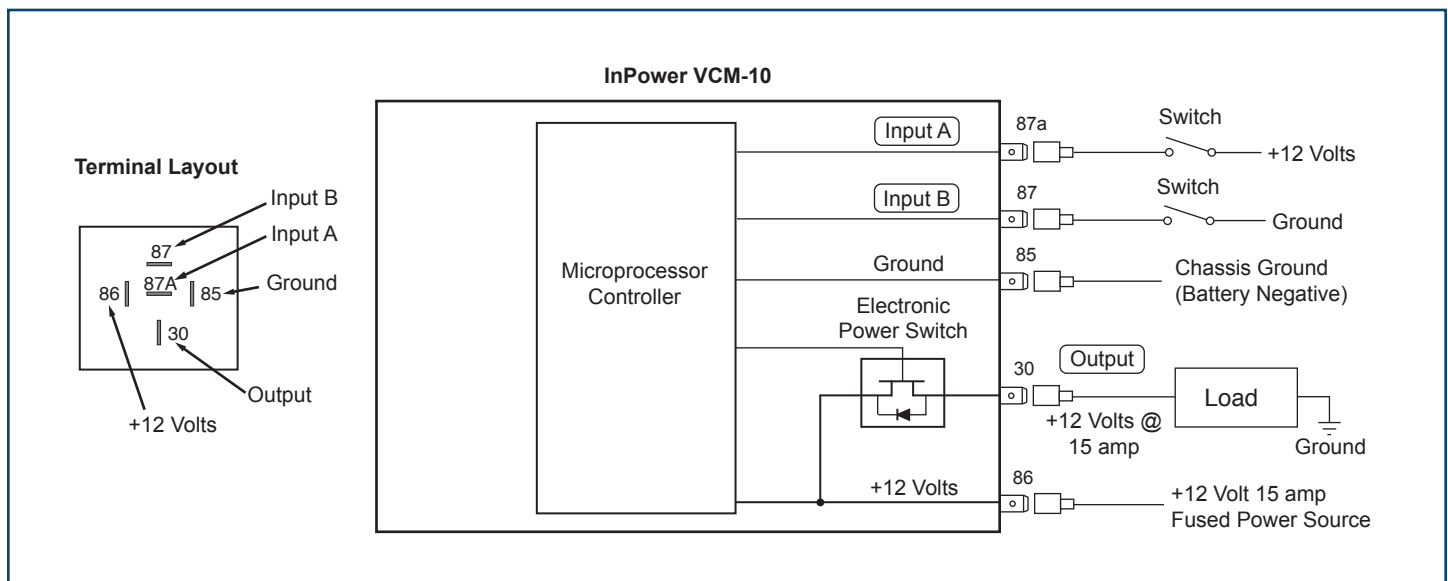

Specifications

Power Input (86):	+8 to 16 Vdc @ 15 amps
Ground (85):	Connection to vehicle ground (Battery Negative)
Input A (87A):	External contact closure to +12 volts
Input B (87):	External contact closure to ground
Module Output (30):	+12 volts @ 15 amps

Mechanical

Weight:	0.10 lbs.
Operating Temperature:	-40° C to +85° C
Dimensions:	1.75" H x 2.30" W x 1.25" D

Installation

1. We recommend that the module be installed by a person trained and skilled in vehicle electrical systems. The installation should comply with SAE (Society of Automotive Engineers) and the vehicle manufacturer's electrical wiring procedures (e.g., Ford, General Motors, etc.).
2. The module should be installed on the inside of the vehicle in a dry and protected environment.
3. For optimum power output performance the product should be mounted to a metal surface.
4. Do not connect loads to the output that will exceed the output current rating of the module.
5. The 12 volt power input must be from a properly fused +12 volt power source.
6. Wiring must be of the proper gage and type to handle the intended load currents.
7. We recommend the use of insulated 1/4 inch female blade terminals that connect to the terminals on the module. Be sure to properly crimp these terminals. **Do not solder wires directly to the module terminals.**
8. If you are experiencing problems with the installation or need troubleshooting assistance, contact InPower Customer Service at 740-548-0965.

Mechanical Drawing

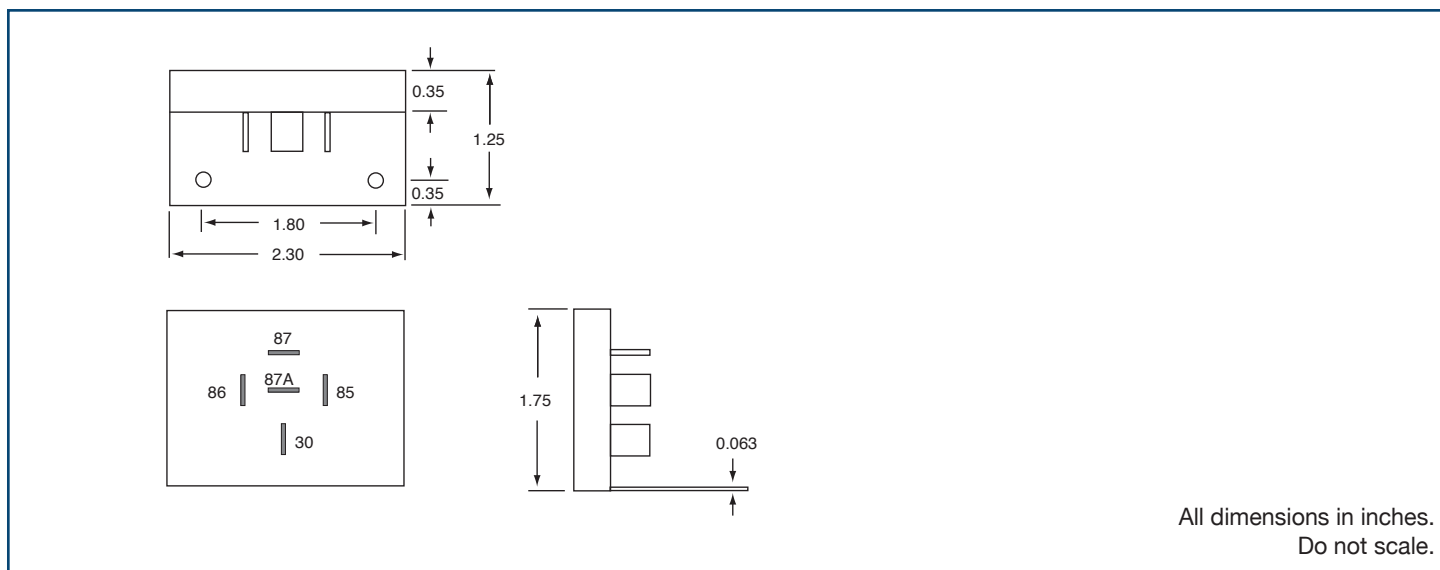

Lake-View Electronics Corp.
Phone: 1-800-686-8439
Fax: 262-375-0109