

VCM-12 Series

Vehicle Control Module

VCM-12 Low Voltage Power Disconnect



Key Features

- Voltage >13.25 - Output On
- Voltage <12.8 - Output Off After Shut Off Time Delay
- Voltage <11.8 - Output Instant Off
- 12 Volt 20 Amp Solid State Output
- Over Current Fault Shutdown Protection
- 4-Wire Terminal Configuration
- Compact Size
- Durable Metal Case

Ordering Guide

Model	Shut Off Timer Value	Model	Shut Off Timer Value
VCM-12-1-60MF	60 Minutes Fixed	VCM-12-1-05MF	5 Minutes Fixed
VCM-12-1-01MF	1 Minute Fixed	VCM-12-1-02H	2 Hour Fixed
VCM-12-1-03MF	3 Minutes Fixed		

InPower's VCM Series *Vehicle Control Modules* are a set of tools for the designers of vehicle electrical control systems. Made to withstand the environments typically found on trucks, emergency vehicles, buses, coaches and speciality vehicles, these modules are available in a variety of standard and custom configurations and functions.

Technical Description

InPower VCM-12 Series are solid state low voltage disconnects for 12 volt vehicle applications. Their 4-wire terminal configuration allows easy installation with two-conductor power cables typically used with 12 volt power point supplies. VCM-12 LVDs protect against draining the battery when the engine is not running by automatically disconnecting loads when the battery voltage reaches a critical level.

The LVD modules contains a microprocessor controller and a solid state 20 amp power switch for powering the output loads. The output provides over current fault shut down protection. The LVD continuously monitors the voltage level of the 12 volt power input. When the voltage is above 13.25 volts, the power switch will turn on to supply up to 20 amps on the output terminal to power the loads. If the voltage drops below 12.8 volts, a timer is started. If the voltage remains below 12.8 volts until the timer expires, the power switch will turn off, disconnecting the power to the loads. If the voltage drops below 11.8 volts with the timer running, the power switch is shut off immediately. Any time the input voltage increases to above 13.25 volts, the power switch will turn on to supply power to the loads and the timer will be reset.

See the ordering guide for standard models. Please call if you require other time values.

System Diagram

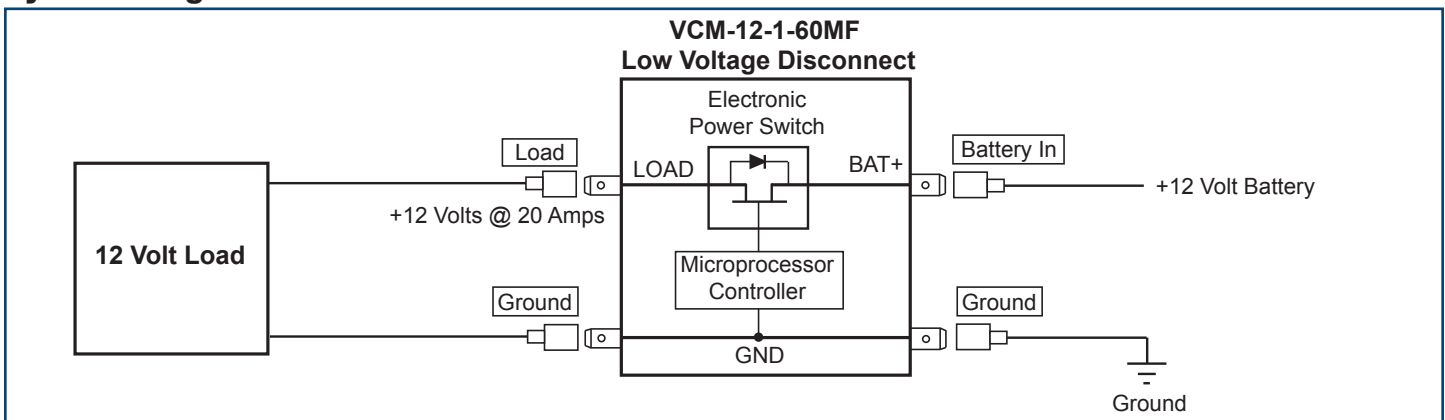

Specifications

Power Input (BAT+): +8 to 16 Vdc @ 20 amps
Module Output (LOAD): +12 volts @ 20 amps, with over current fault shutdown protection

Mechanical
Weight: 0.10 lbs.
Operating Temperature: -40° C to +85° C
Dimensions: 1.75" H x 2.30" W x 0.65"

Output Disconnect Operation:
Input voltage >13.25 - Output on
Input voltage <12.8 - Output off after the shut off timer expires*
Input Voltage <11.8 - Output instant off

* Time value per model number suffix:
VCM-12-1-60M 60 minutes fixed
VCM-12-1-05M 5 minutes fixed

Installation

1. We recommend that the module be installed by a person trained and skilled in vehicle electrical systems. The installation should comply with SAE (Society of Automotive Engineers) and the vehicle manufacturer's electrical wiring procedures (e.g. Ford, General Motors, etc.).
2. The module should be installed on the inside of the vehicle in a dry and protected environment.
3. For optimum power output performance the product should be mounted to a metal surface.
4. Do not connect loads to the output that will exceed the output current rating of the module.
5. The 12 volt power input must be from a properly fused +12 volt power source.
6. Wiring must be of the proper gage and type to handle the intended load currents.
7. We recommend the use of insulated 1/4 inch female blade terminals that connect to the terminals on the module. Be sure to properly crimp these terminals. **Do not solder wires directly to the module terminals.**
8. If you are experiencing problems with the installation or need troubleshooting assistance, contact InPower Customer Service at 740-548-0965.

Mechanical Drawing

